

8



8.1

8.2

8.3

8.4

8.5

8

1.

;

2.

;

3.

;

4.

5.

8

2011-11-1



8.1

8.1.1

1.

380V 5.5kW

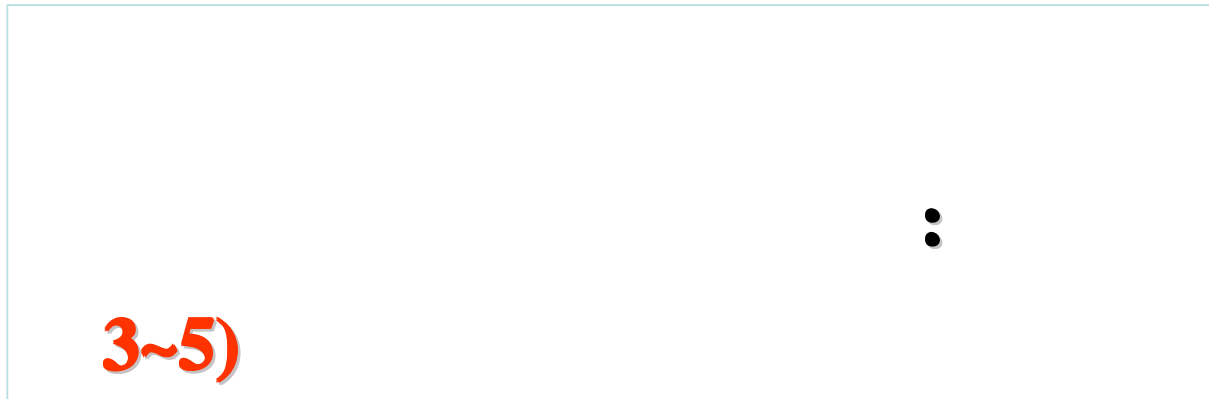

2011-11-1

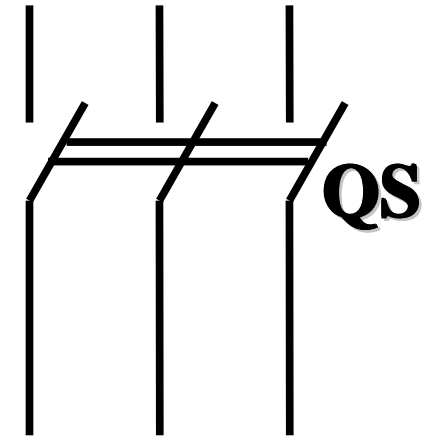

1.

2.

/

/

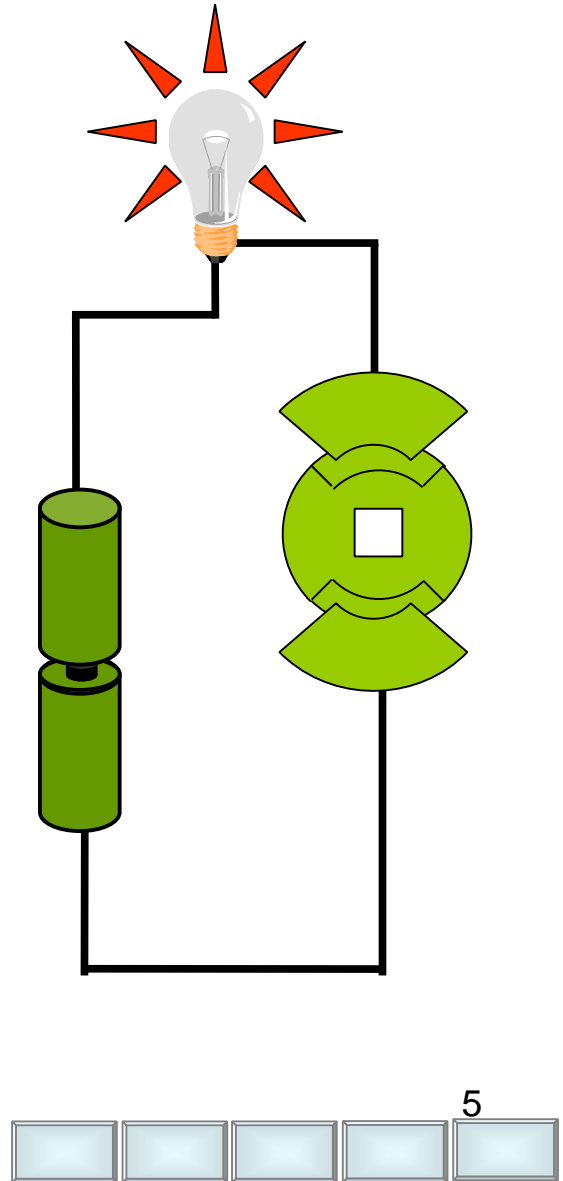

2011-11-1

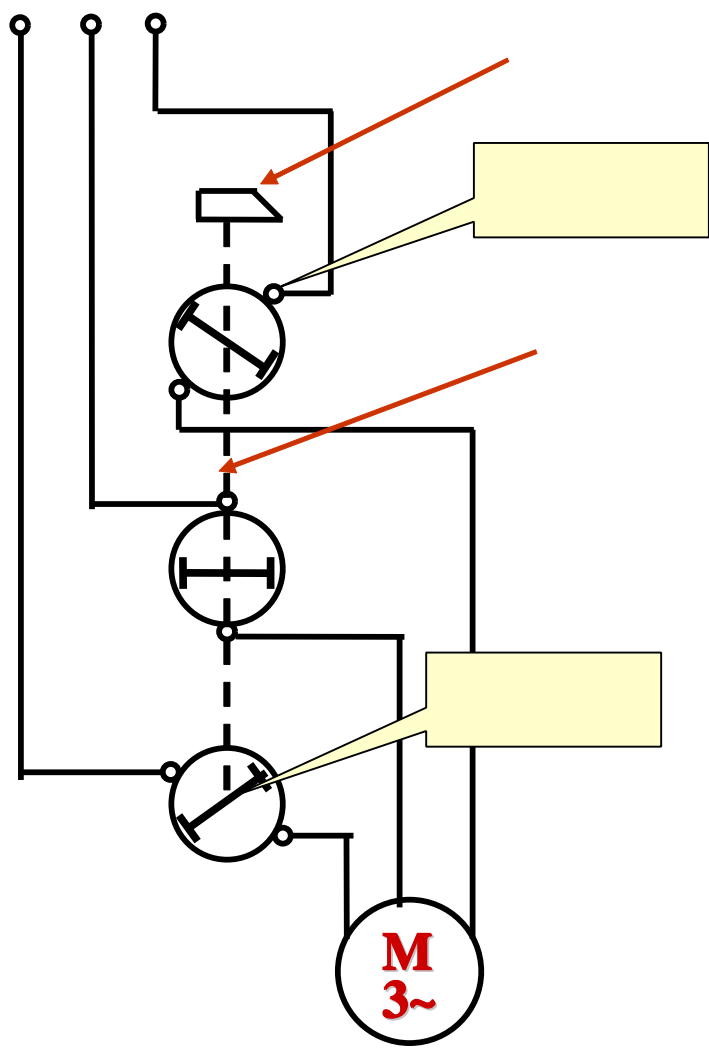

2011-11-1

8.1.2

1.

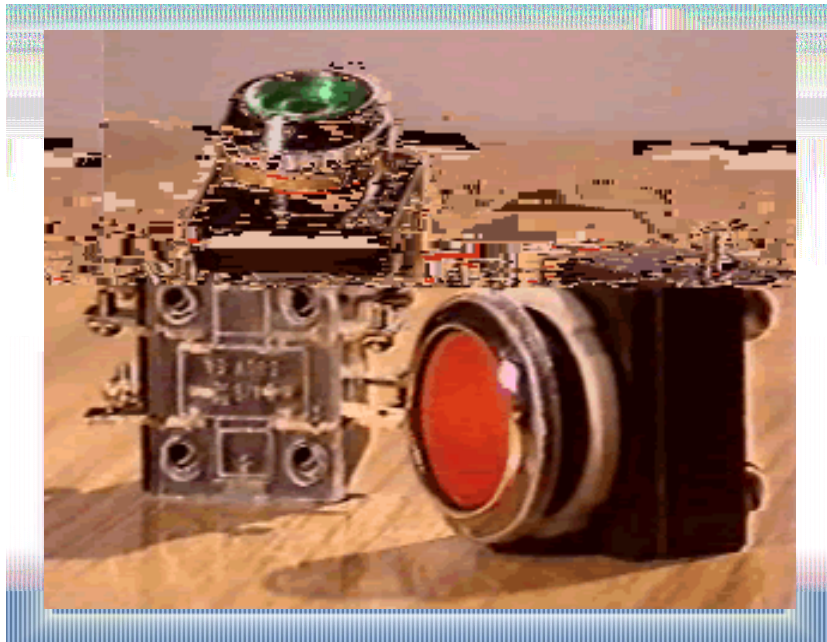

(a)

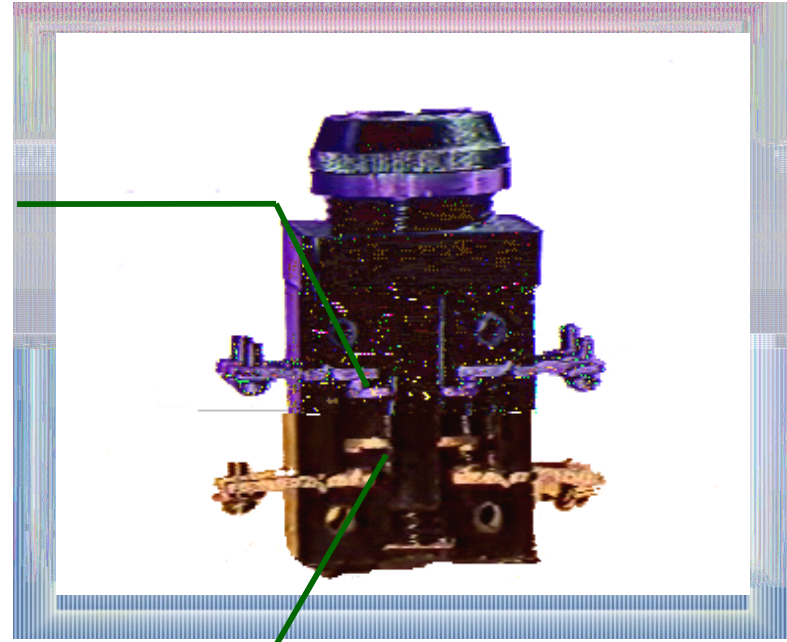

(b)

2011-11-1

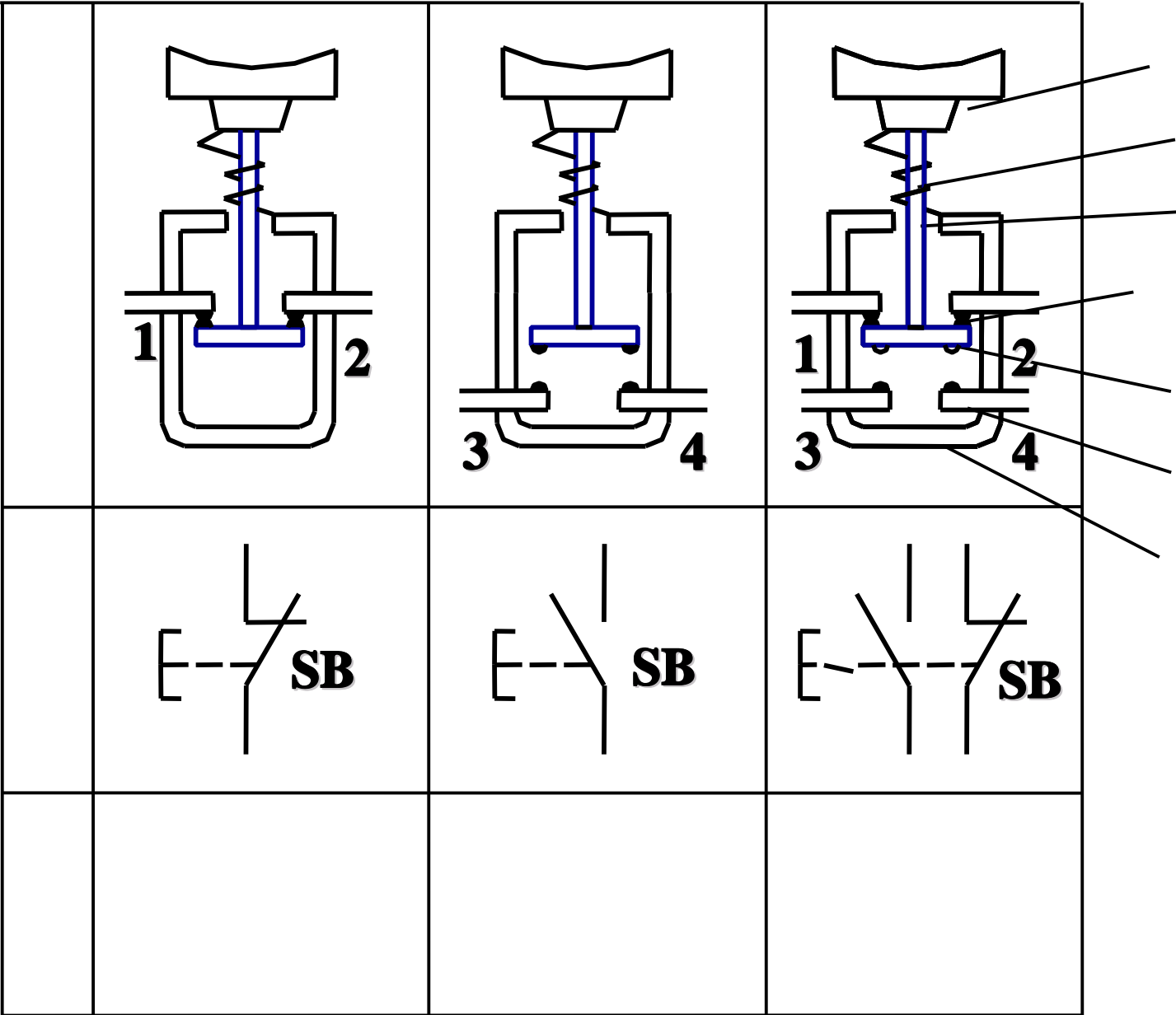

2.

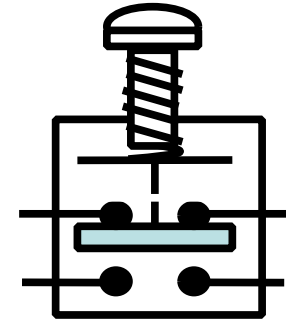

2011-11-1

8.1.3

1.

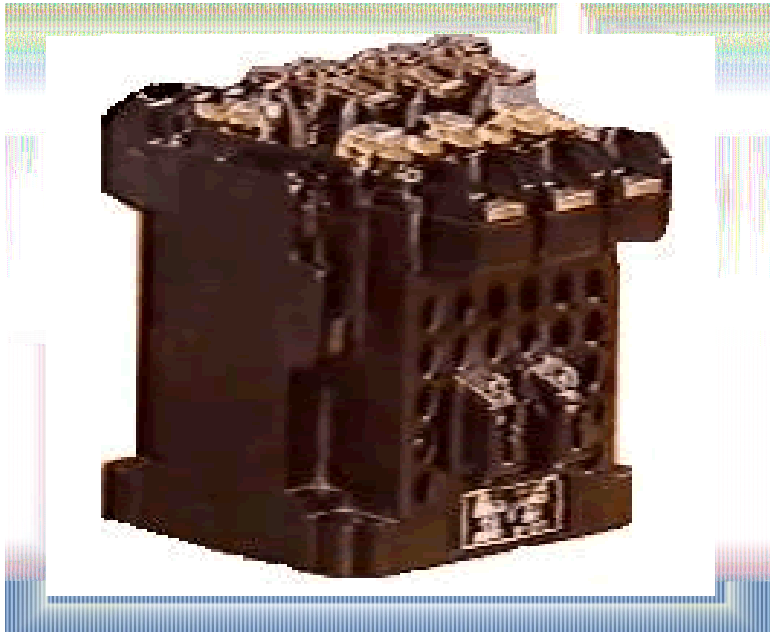

(a)



(b)



2.

1

2011-11-1

2

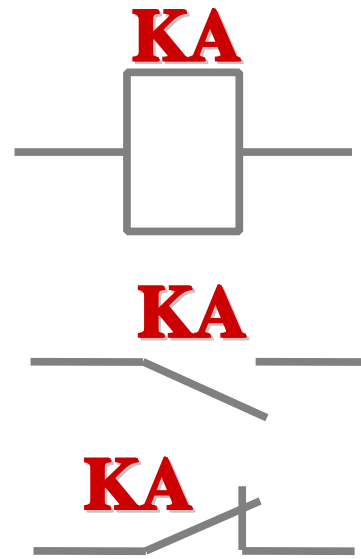

(b)

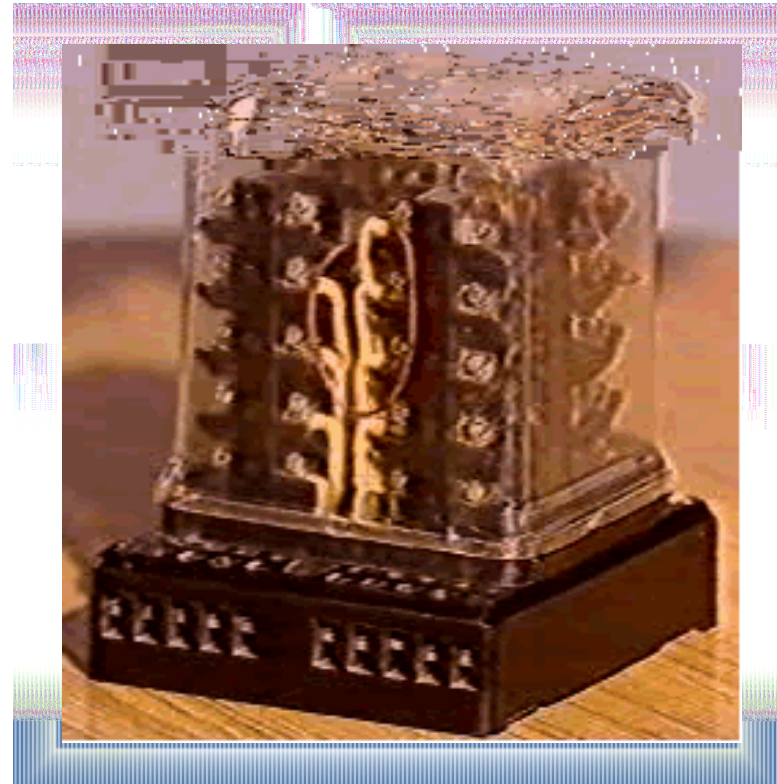

3

)

(

(a)

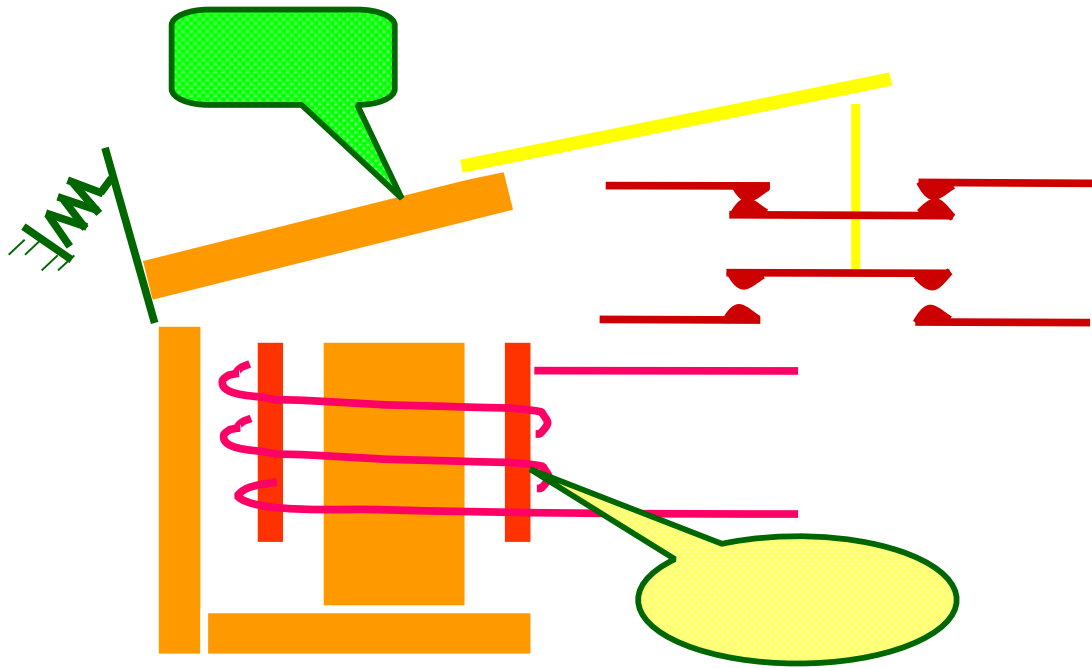

2011-11-1

13



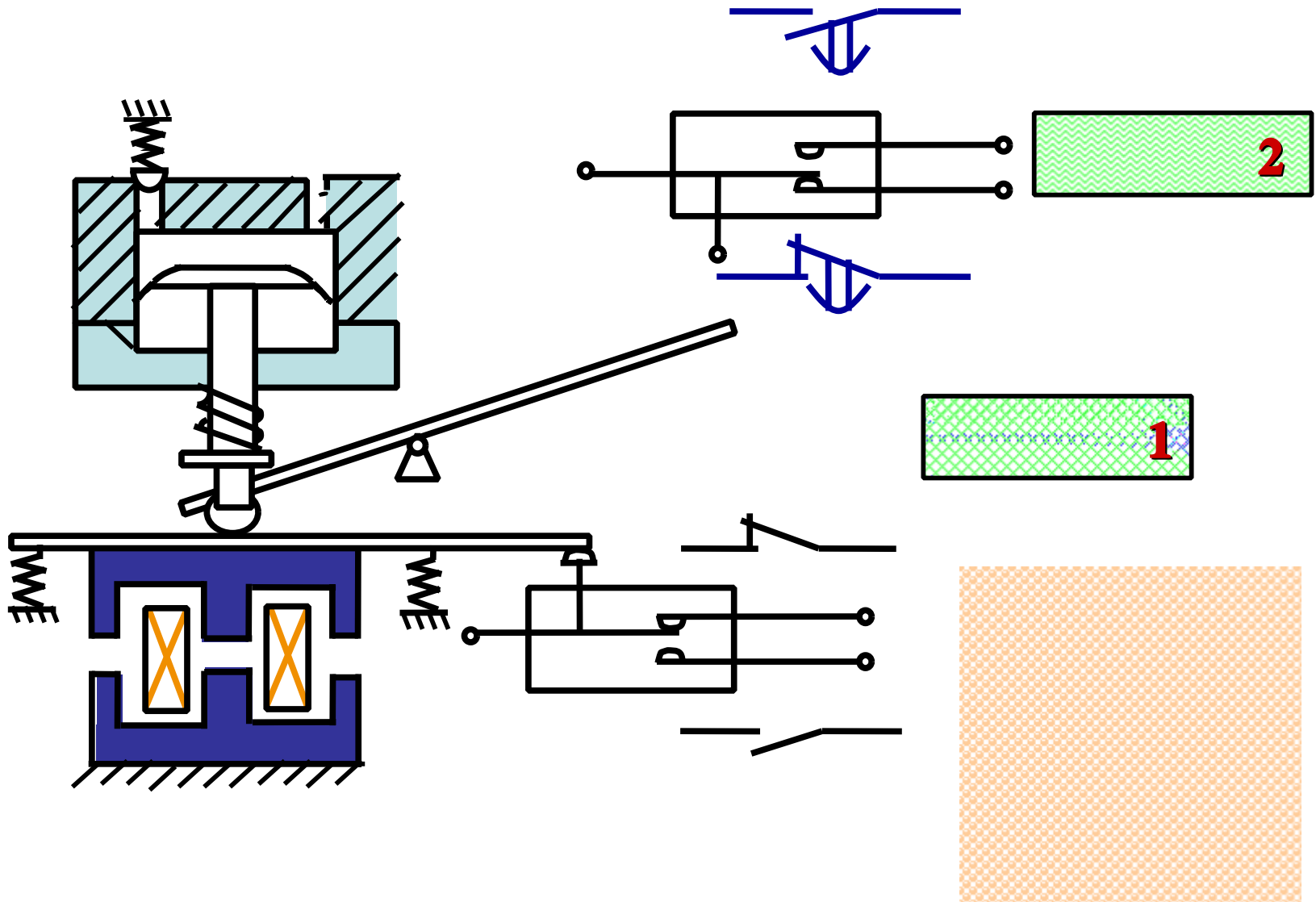

2011-11-1



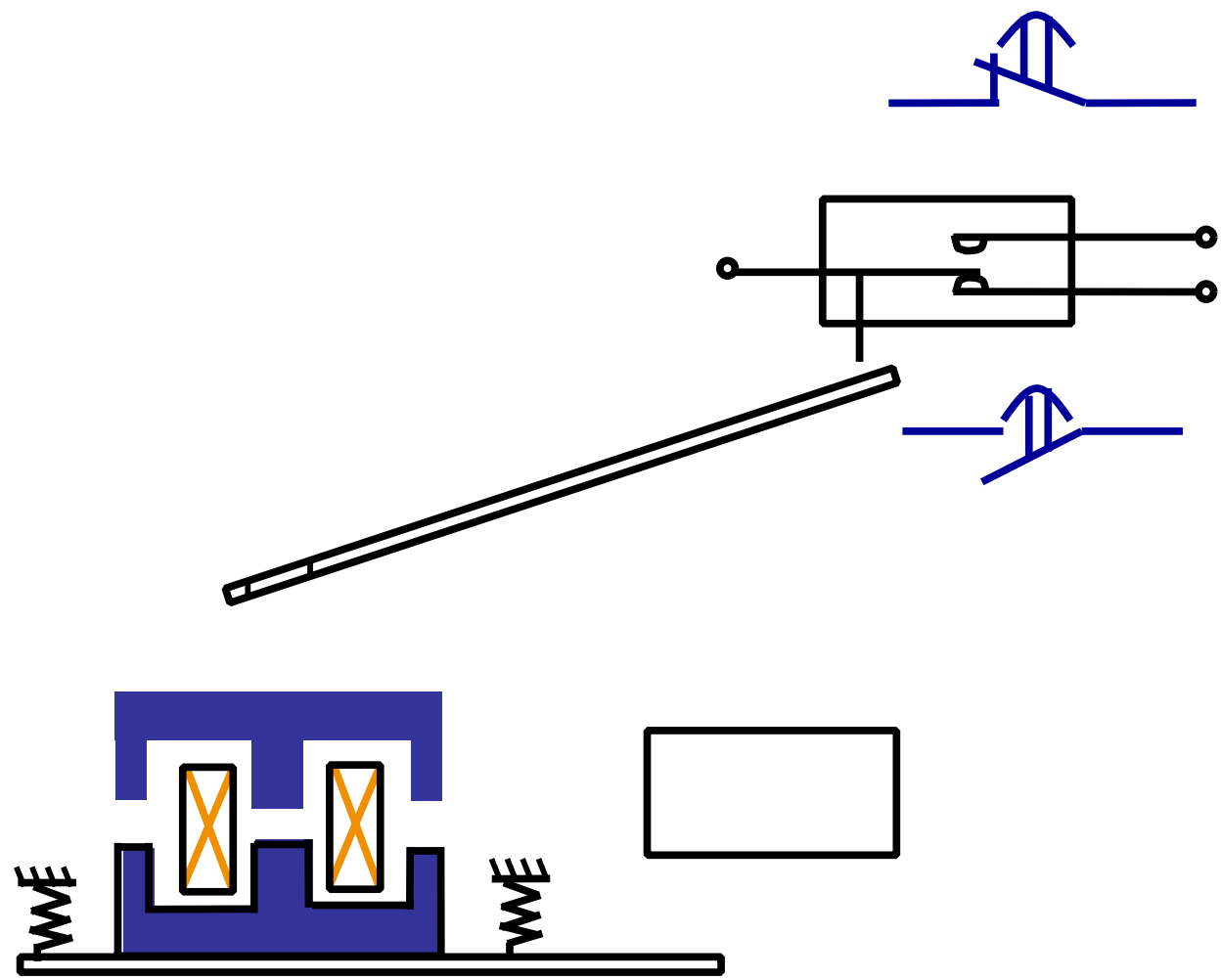

2011-11-1





8.1.4

p177

1.

2.

3.

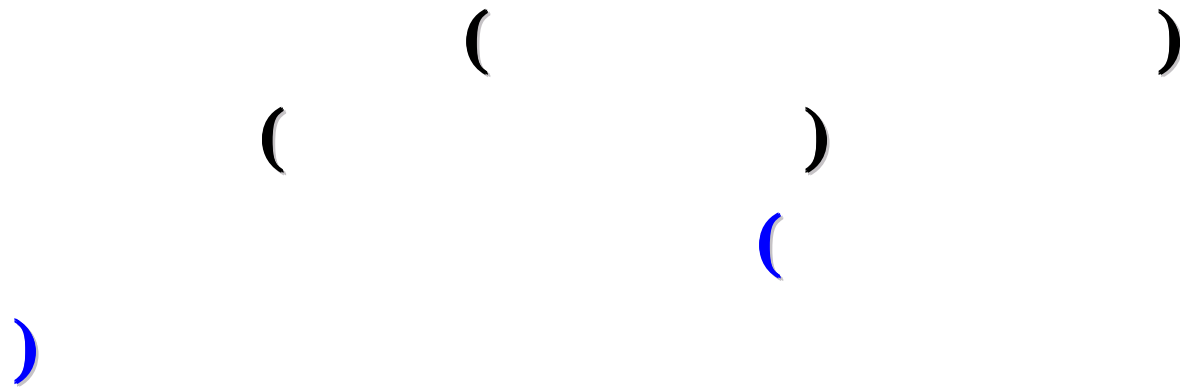

4.

5.

()

8.1.5

(2)

(3)

2011-11-1

21



8.2

8.2.1

1.

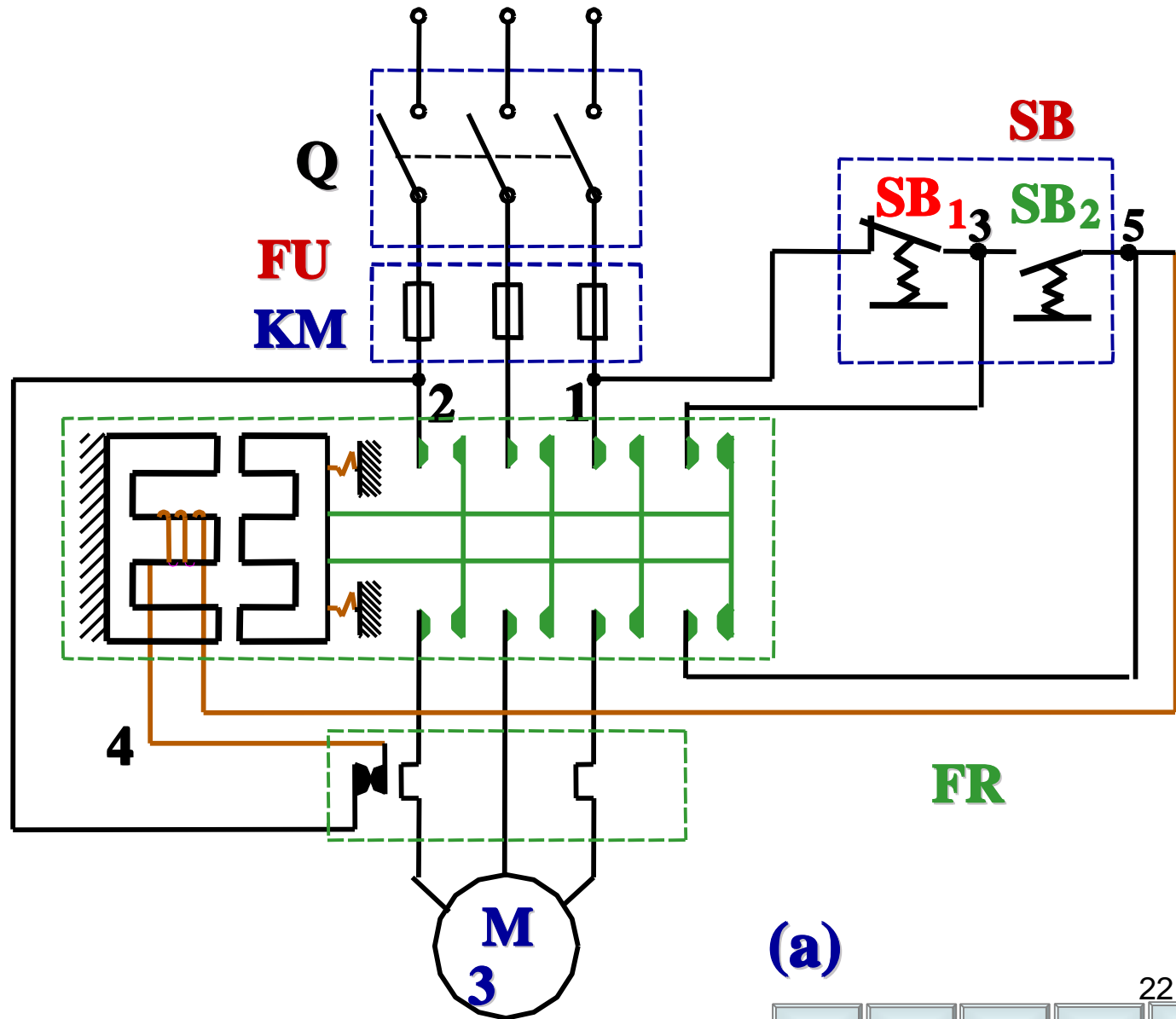

(a)



2011-11-1

22



FU

()

()



2011-11-1

2.

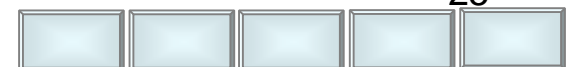
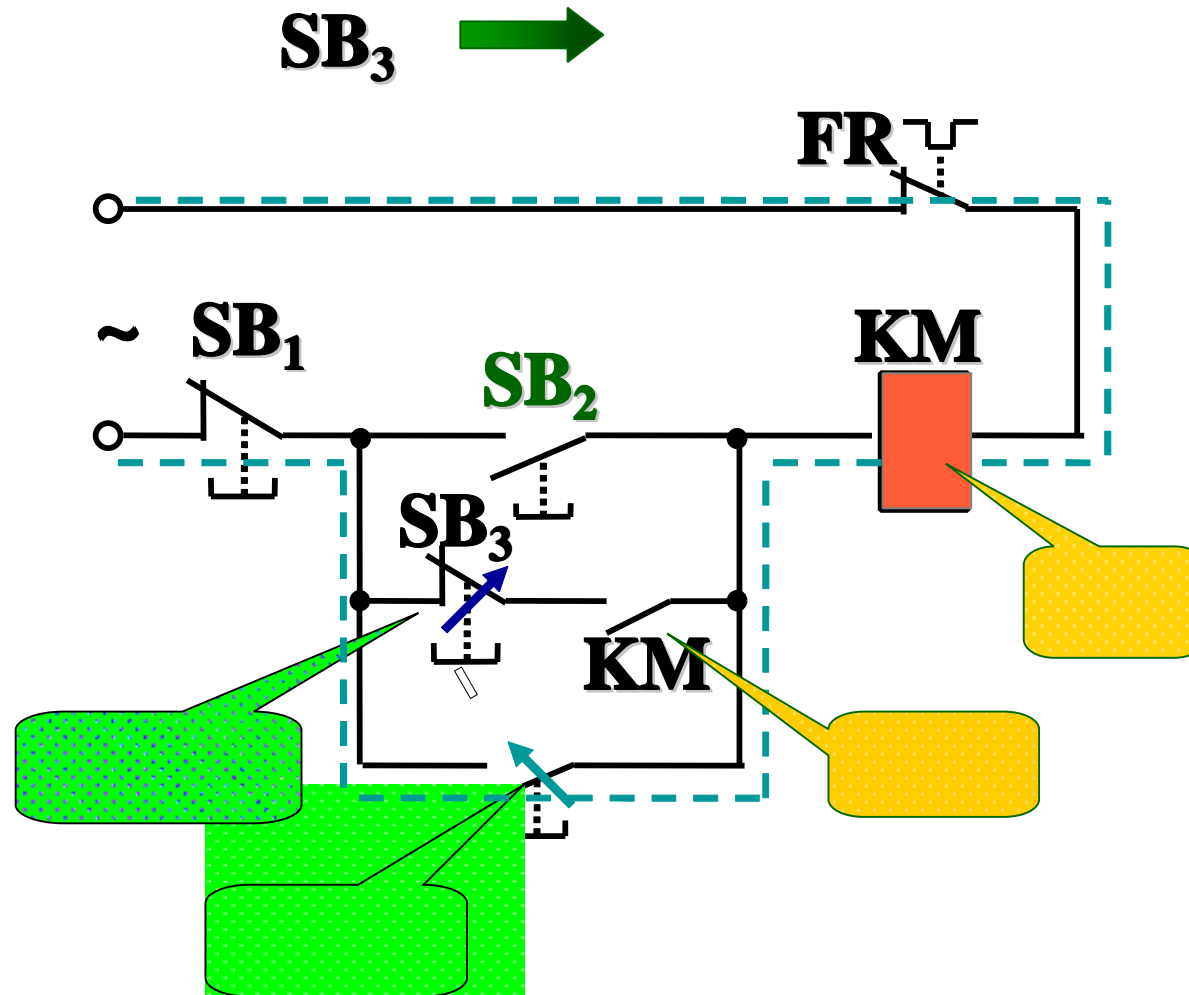

2.

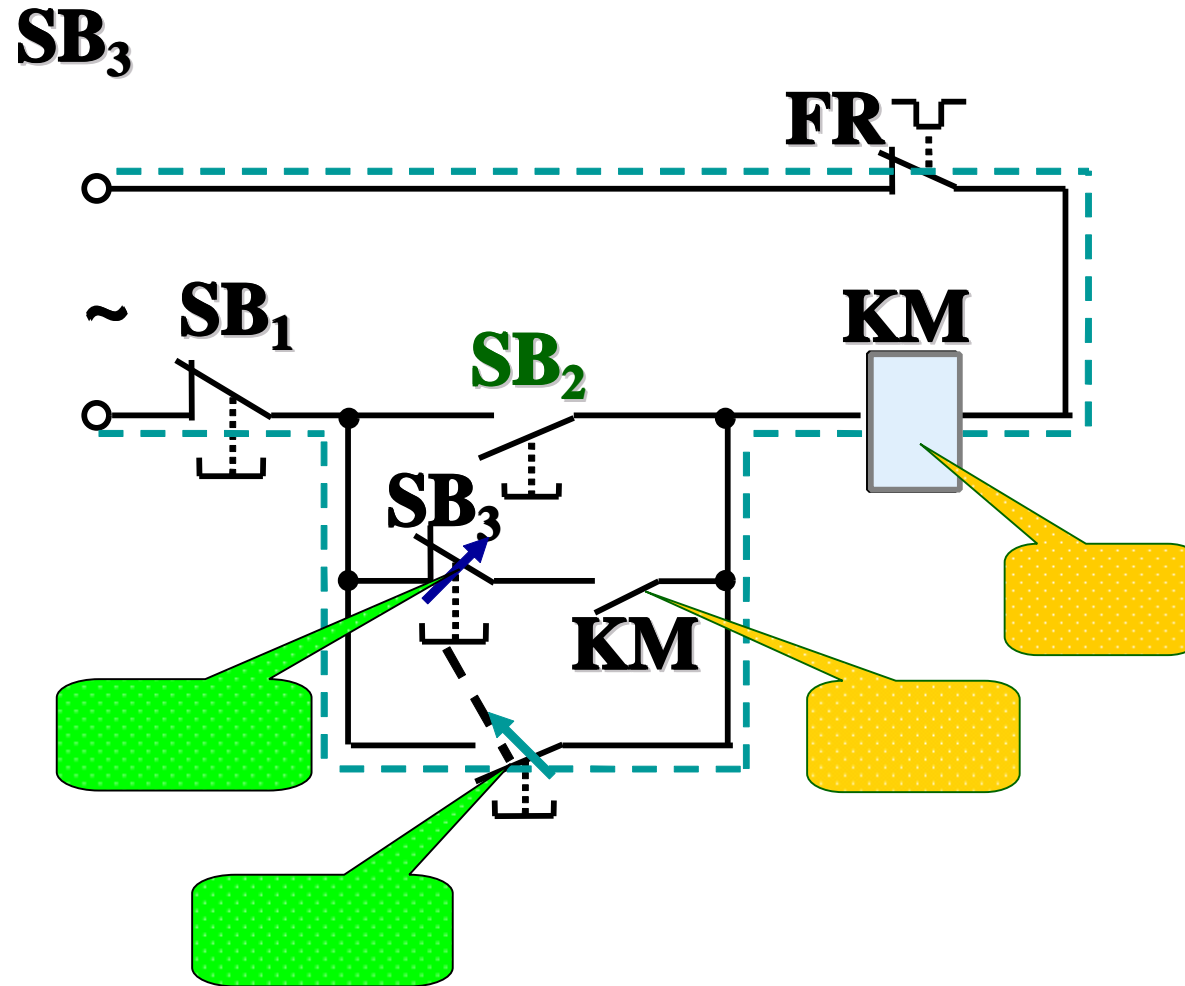

2011-11-1

26



2.

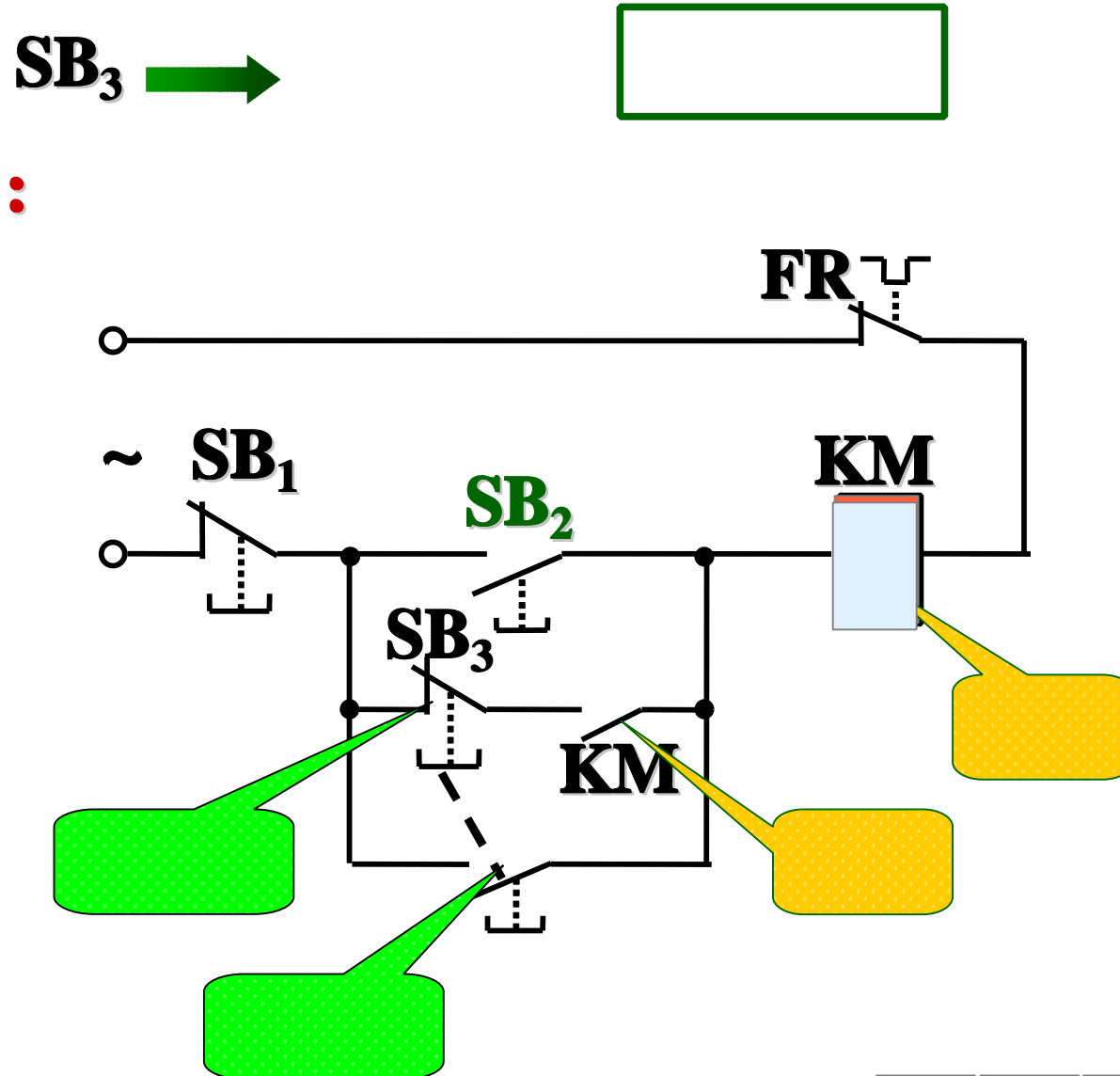

3.

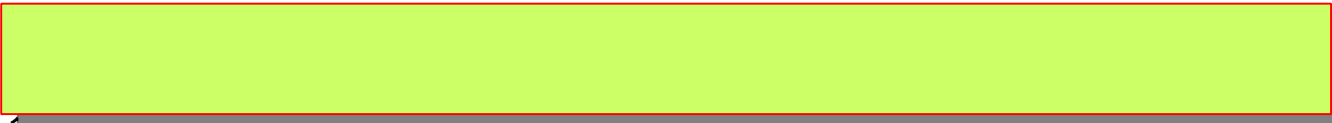
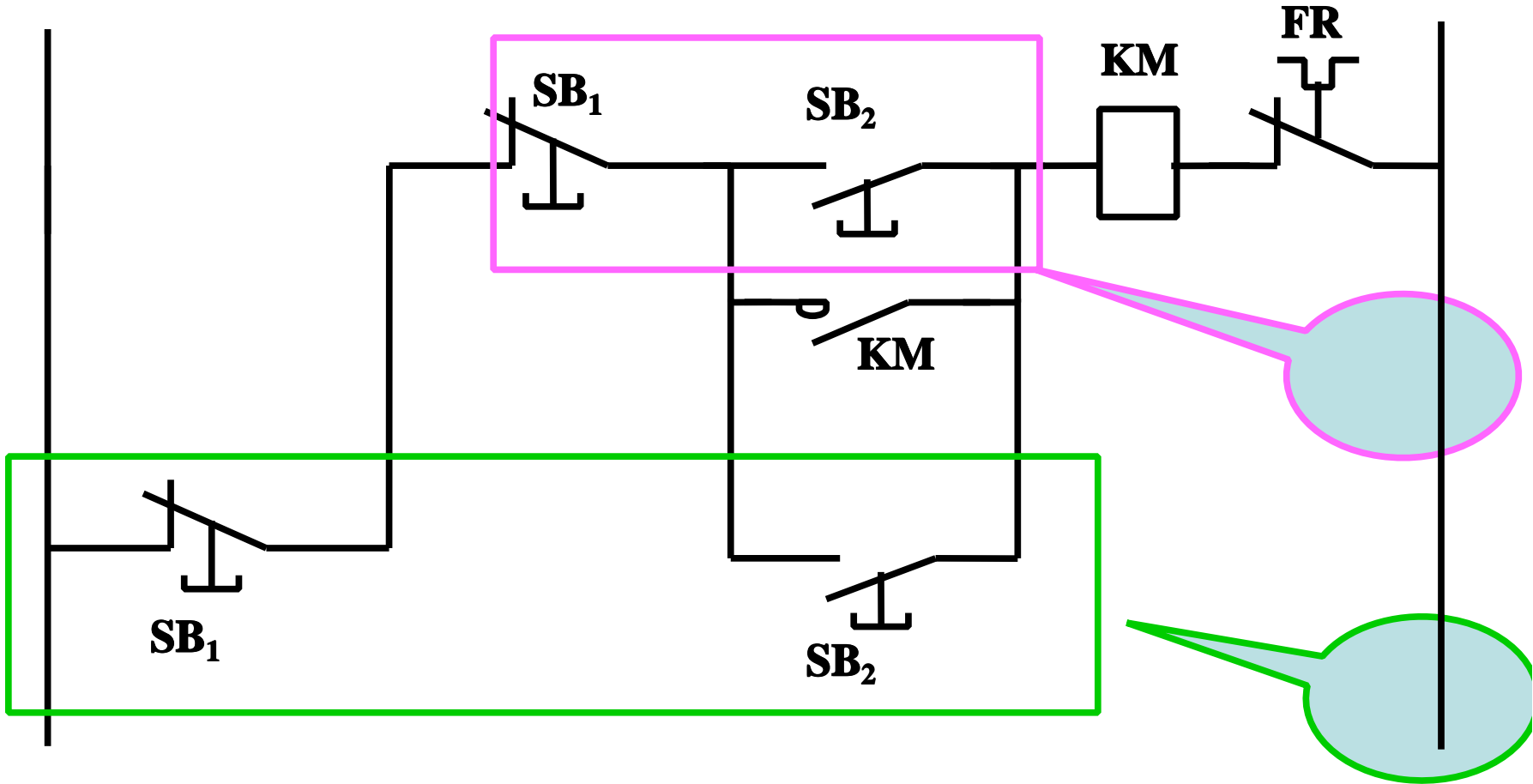

8.2.2

1.

2.

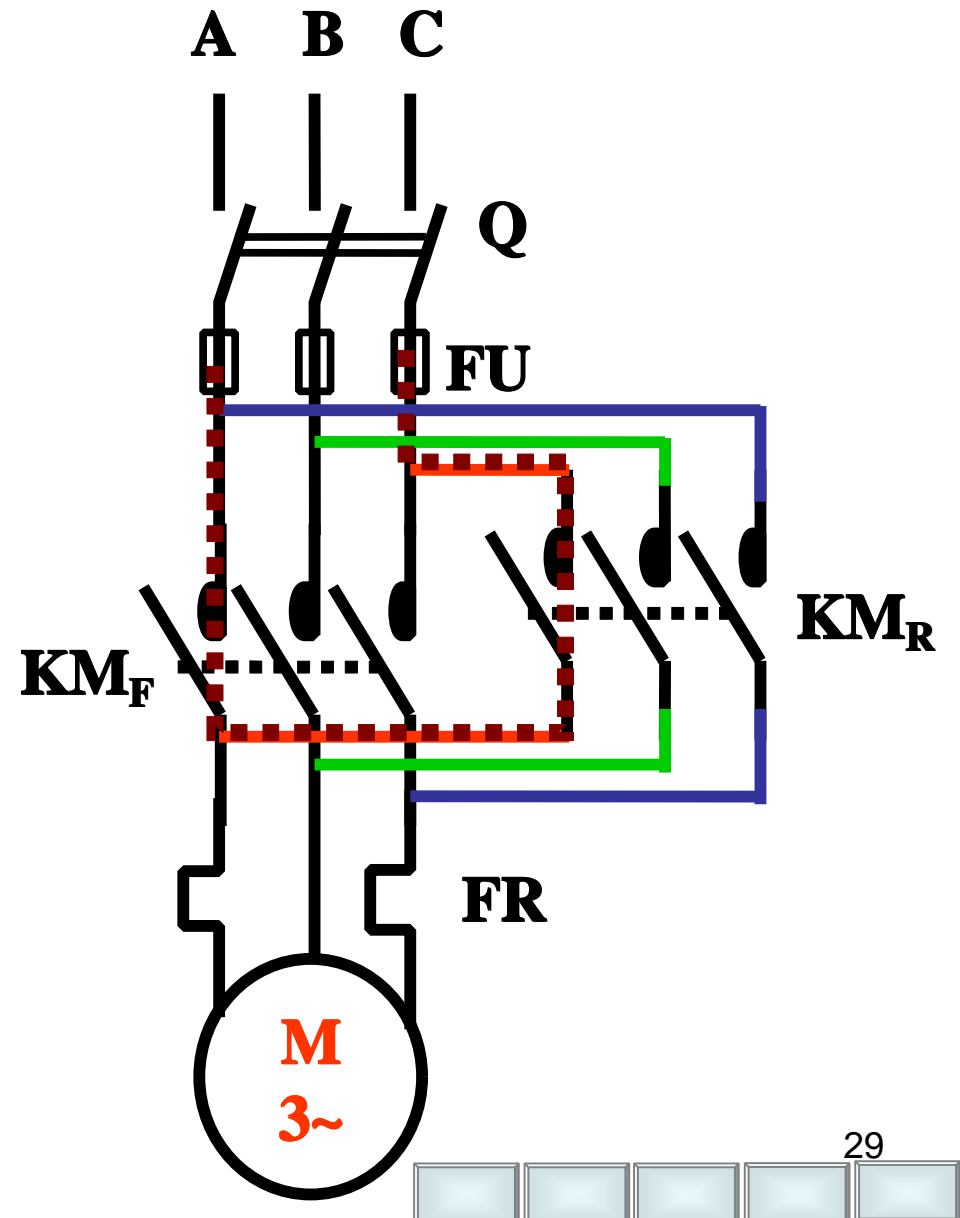

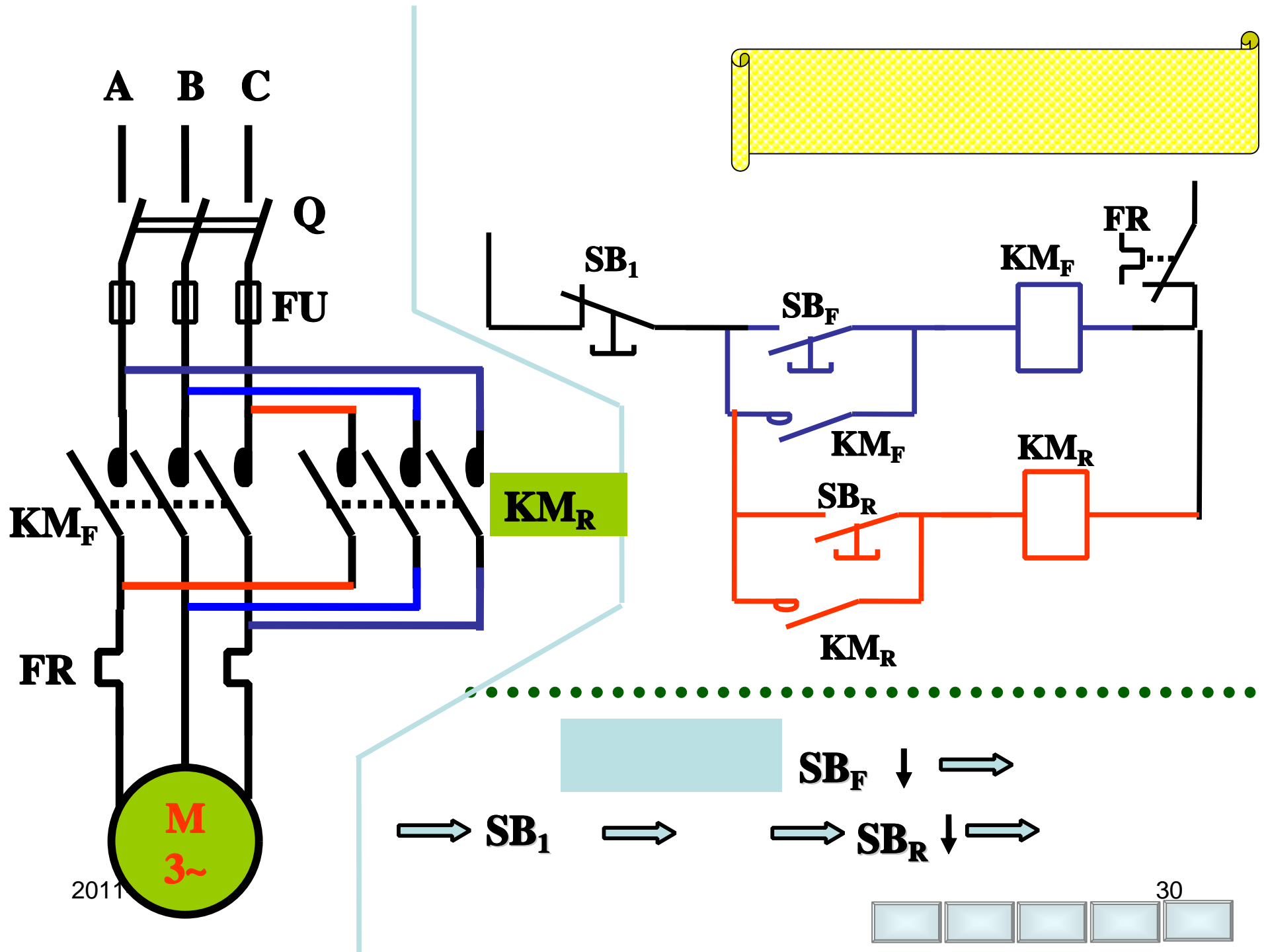

2011

30



4.

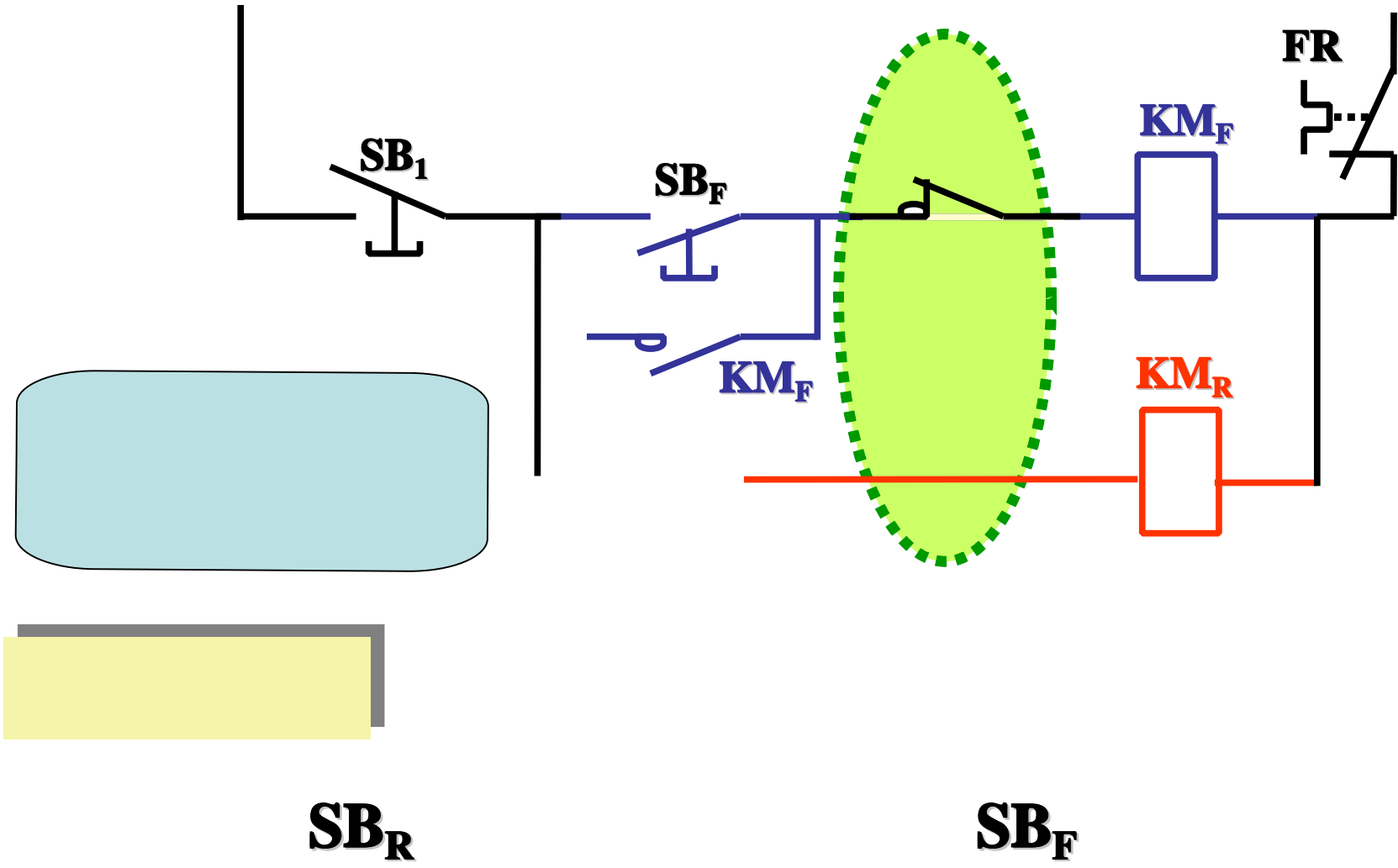

2011-11-1





5.

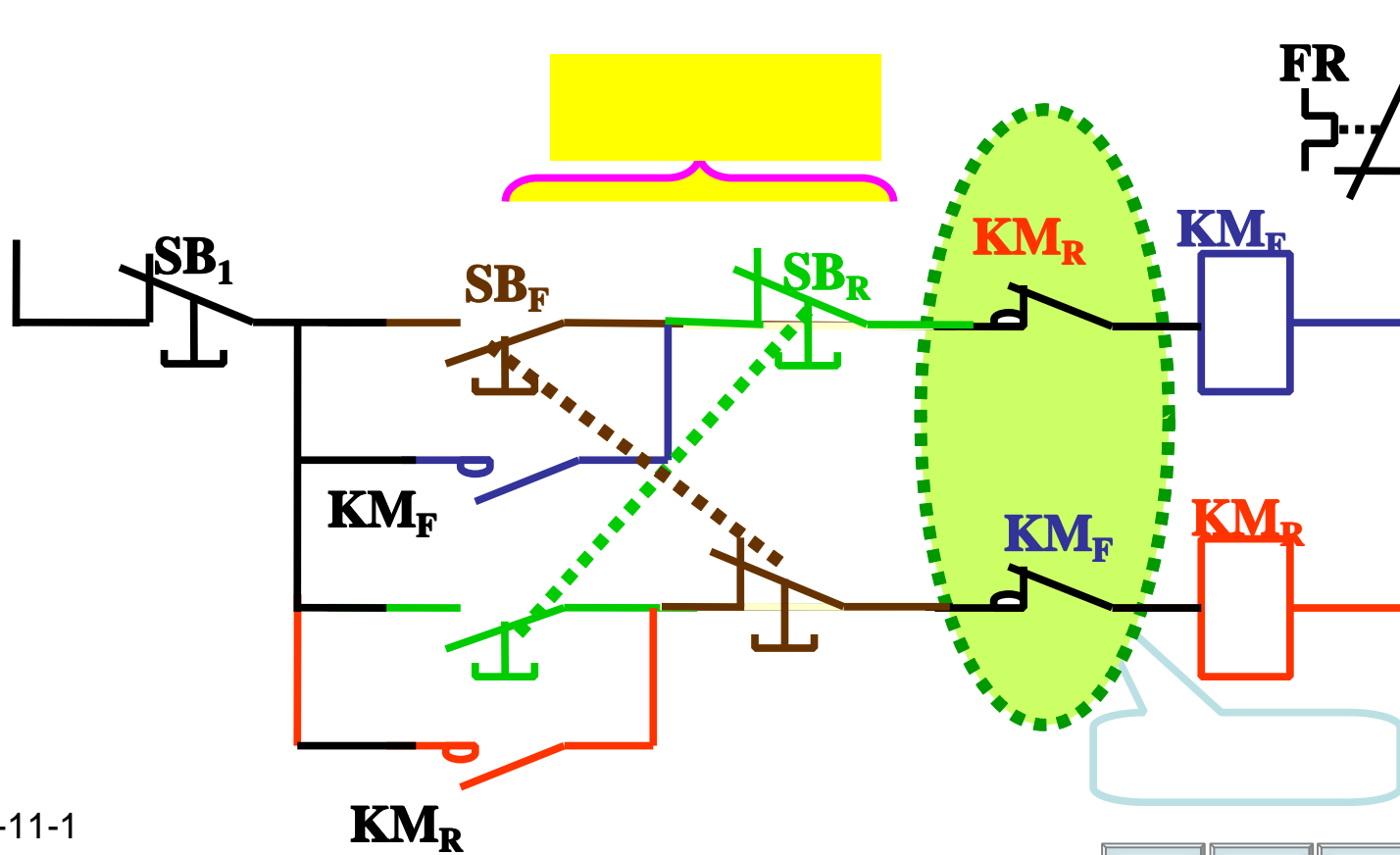

2011-11-1

32



8.3

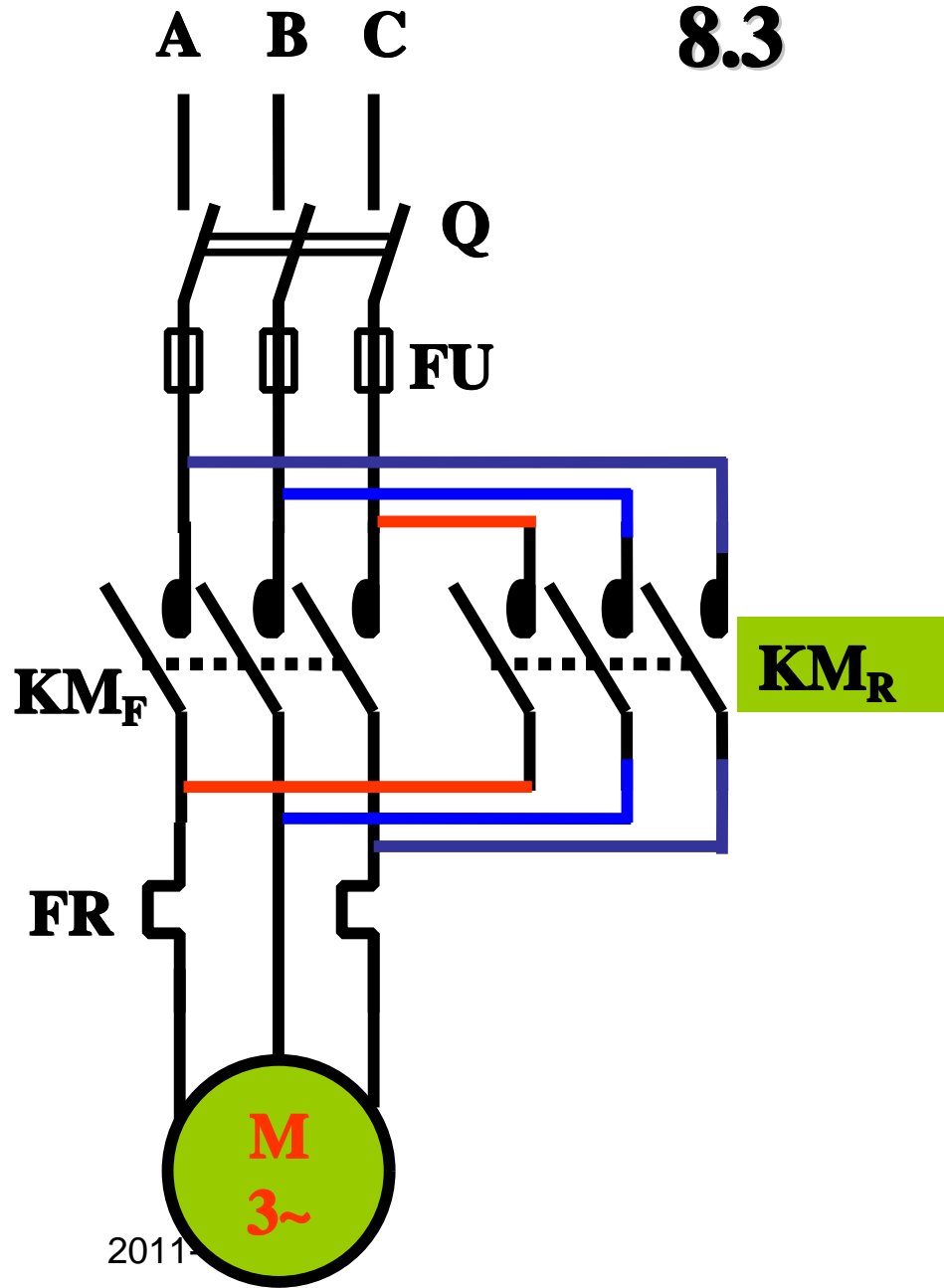

2011



1.

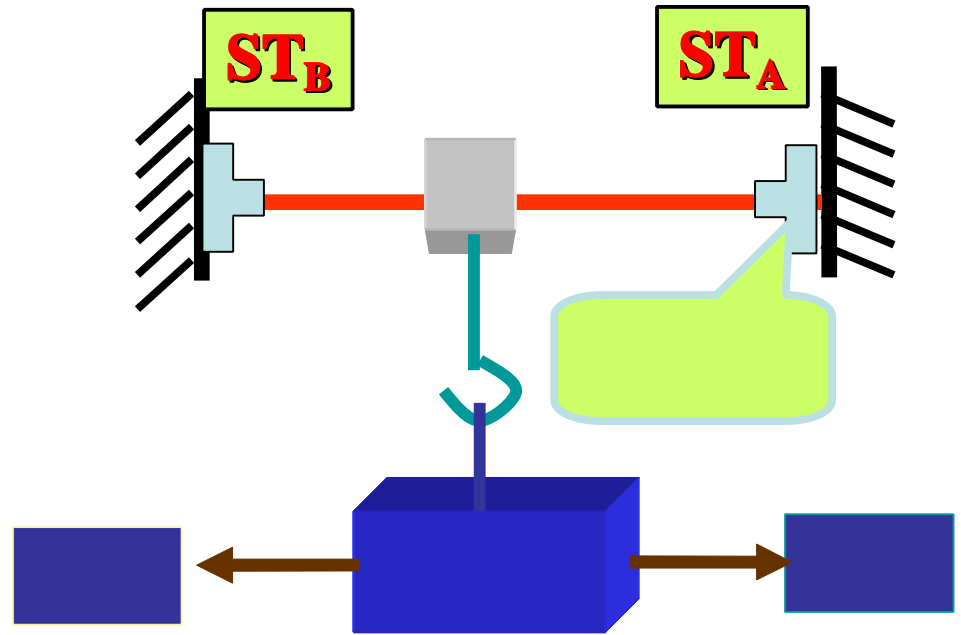
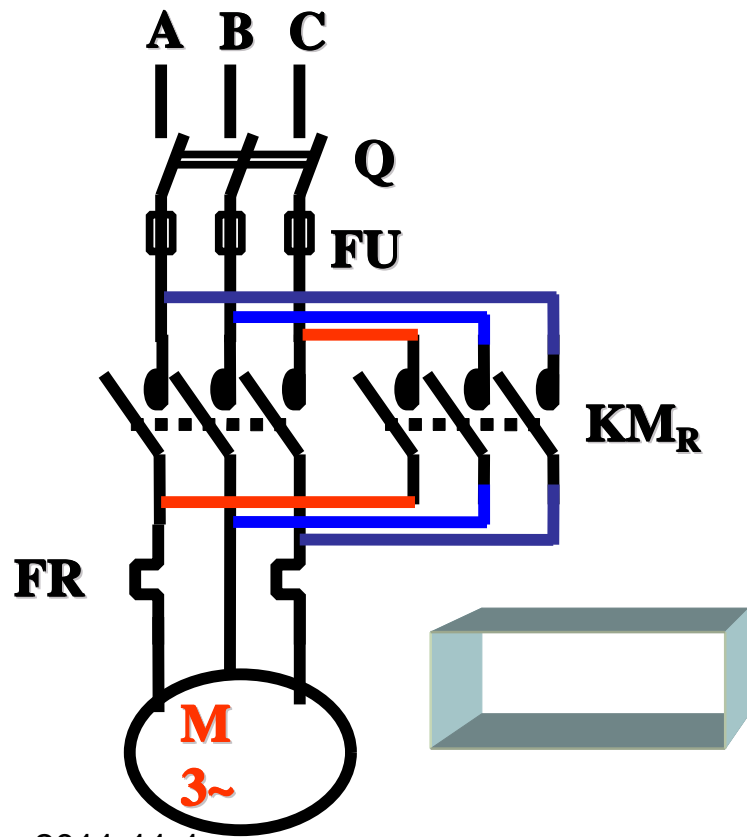
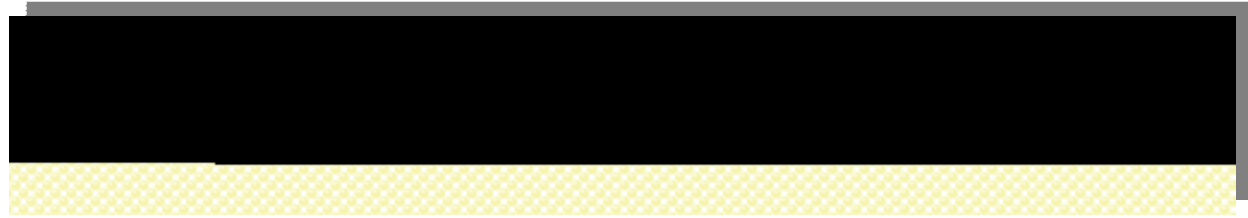

2011-11-1



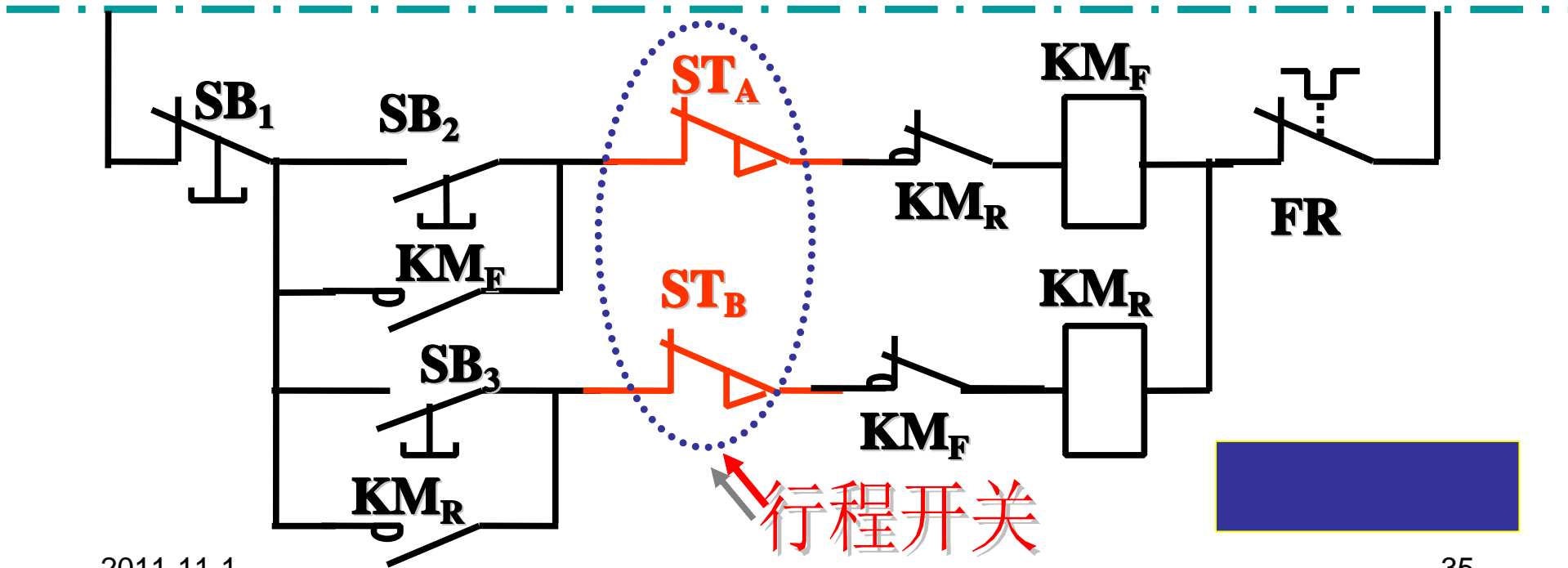
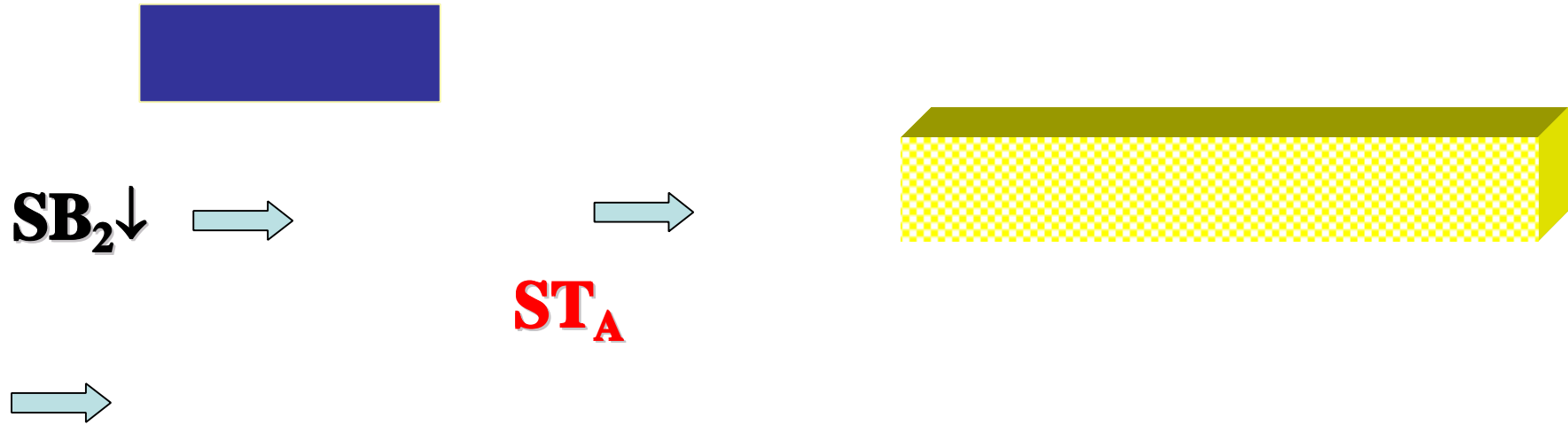

2011-11-1

35



2.

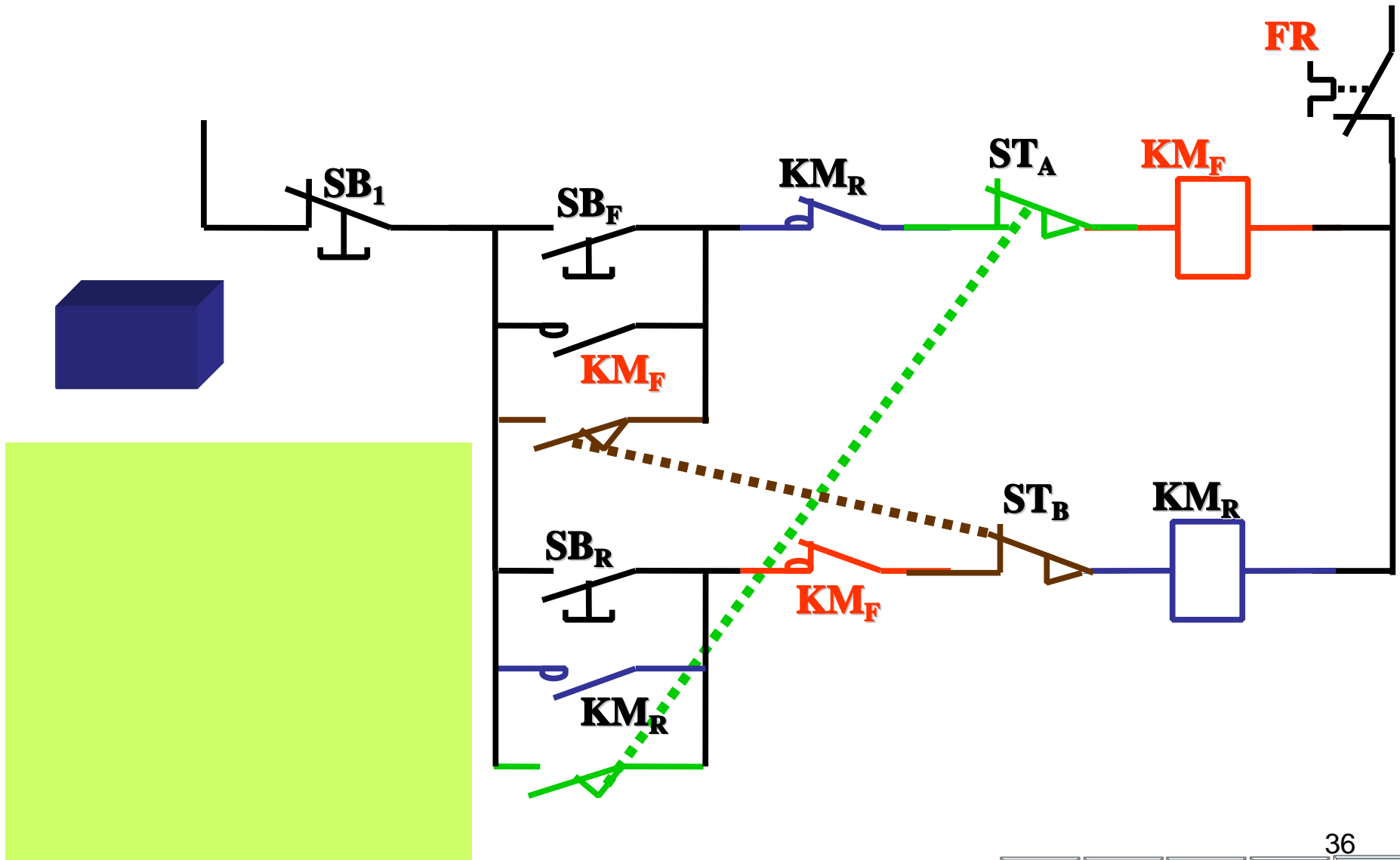

提示

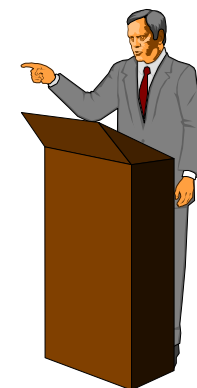
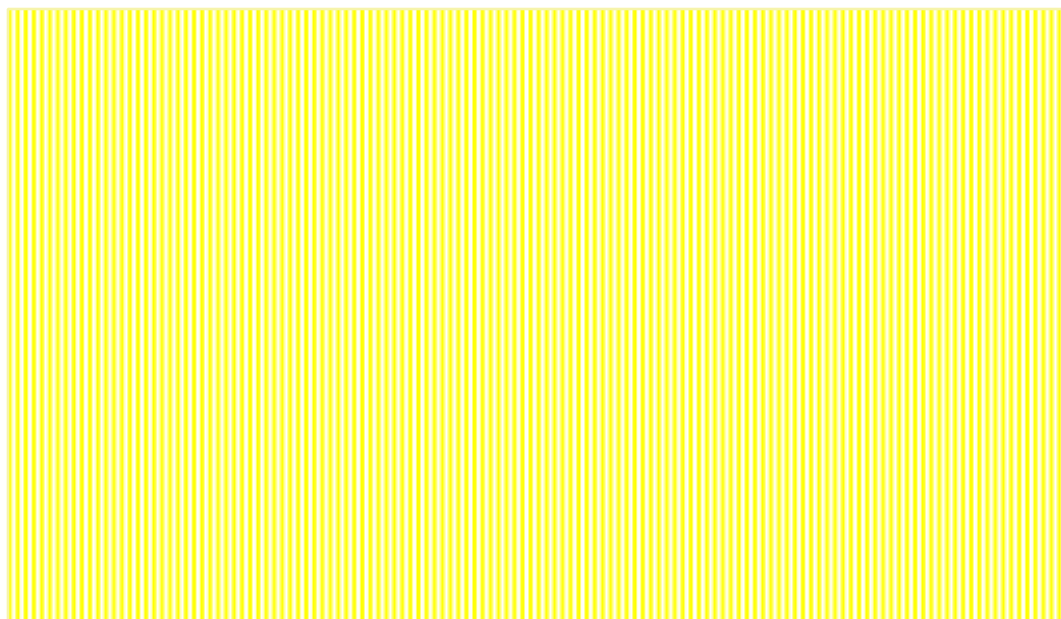

2011-11-1

37

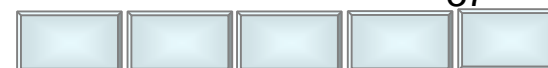

8.4

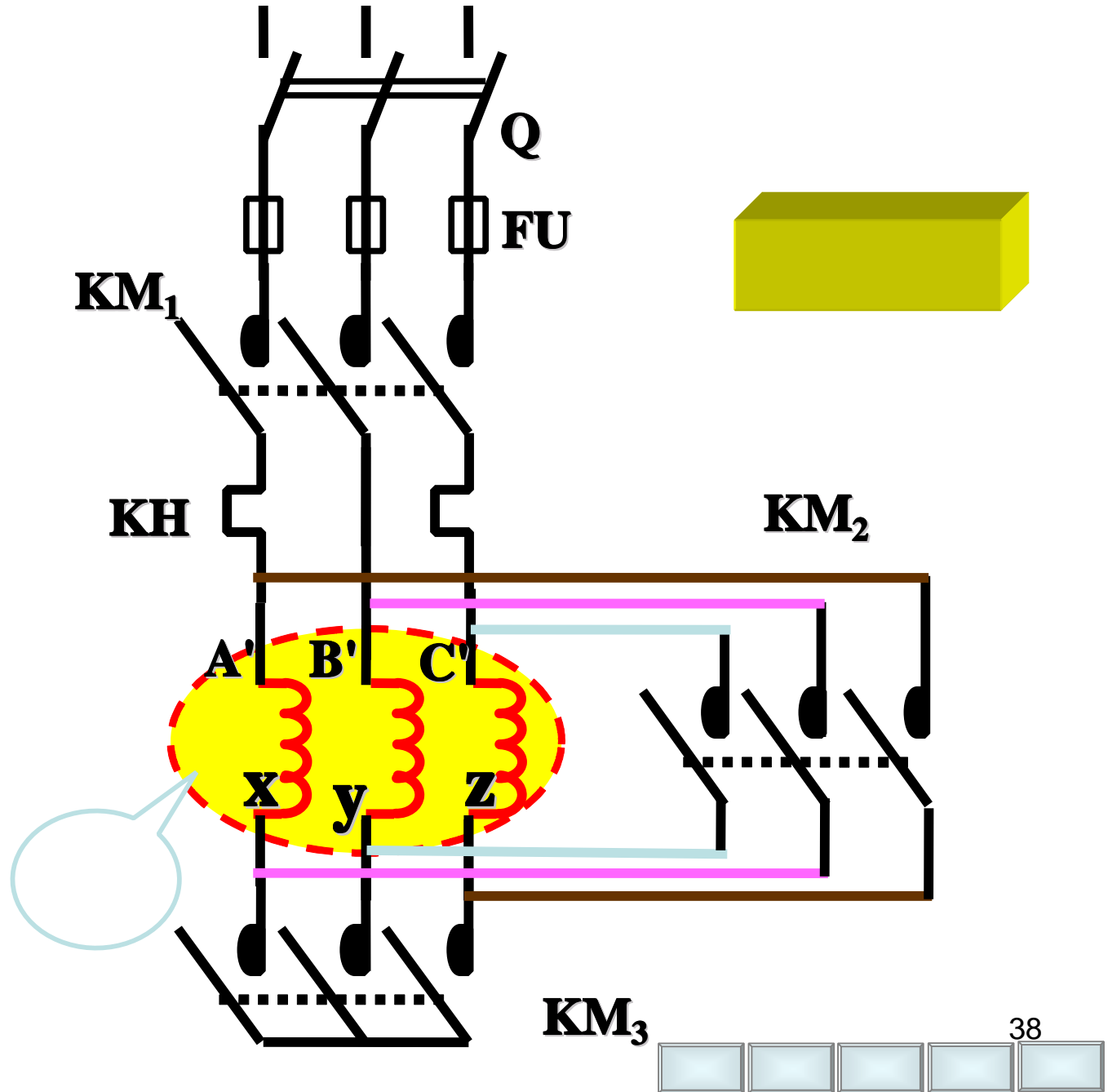

2011-11-1



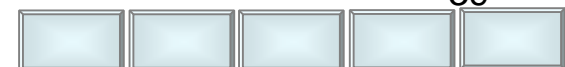
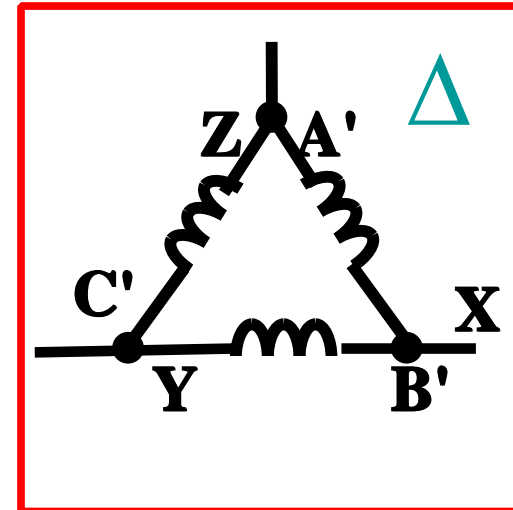
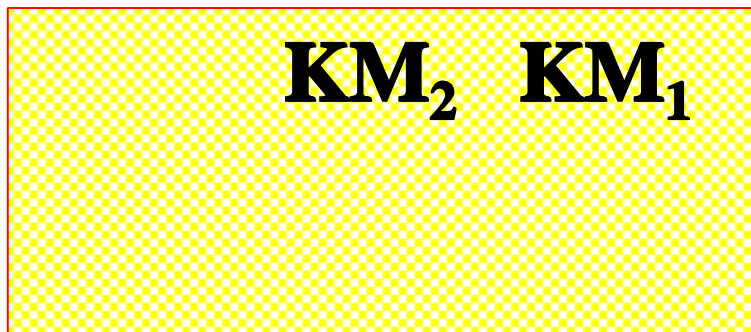
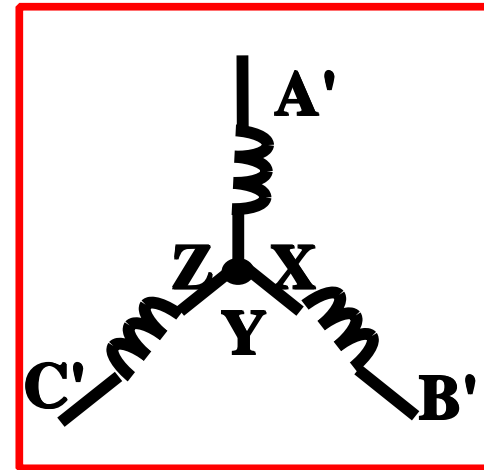
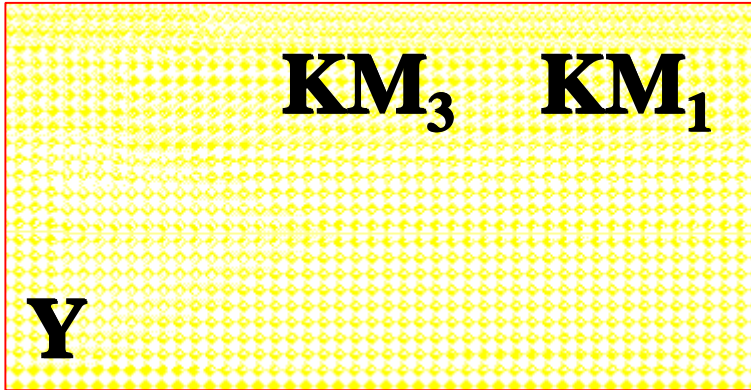

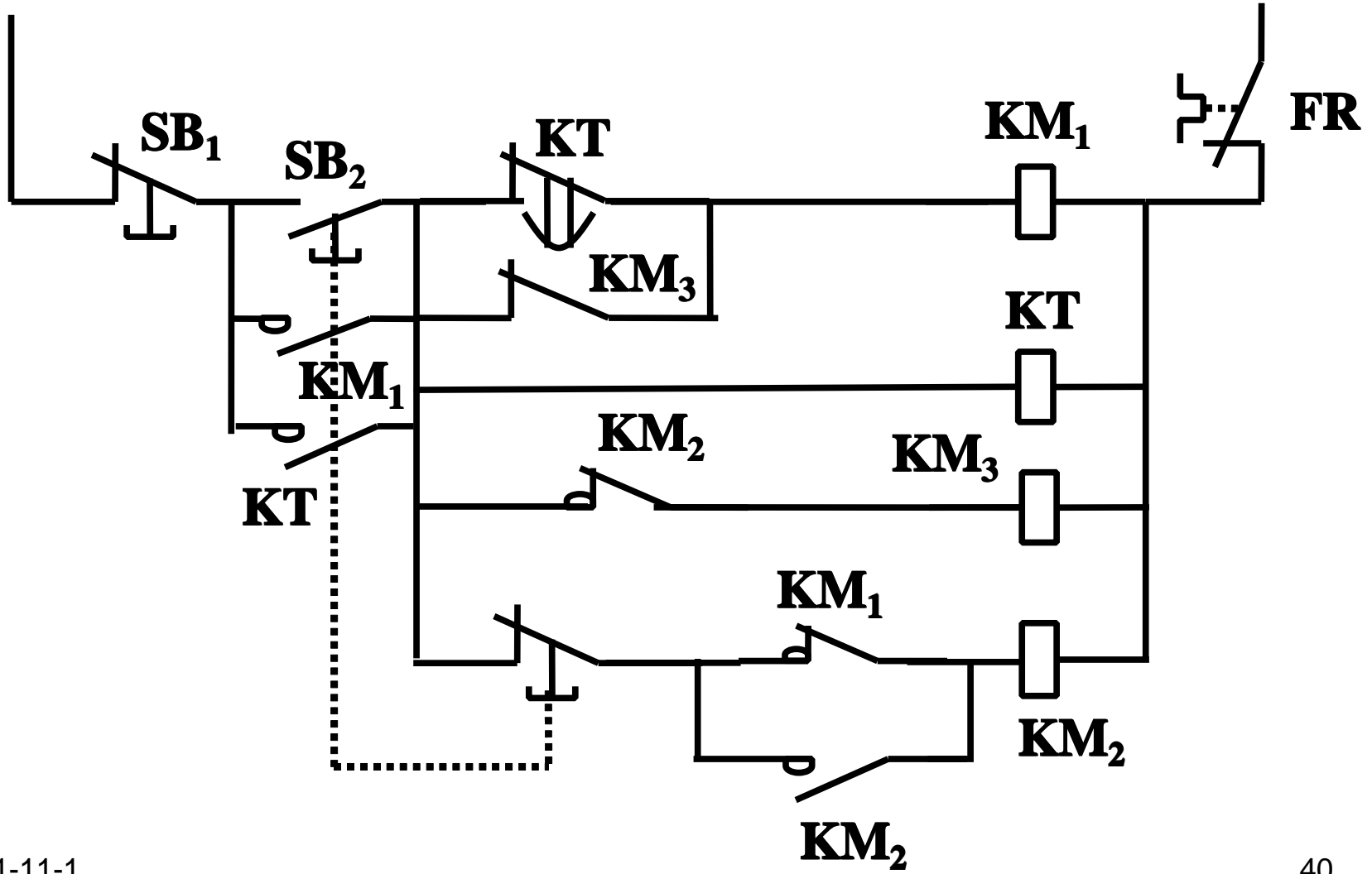

2011-11-1

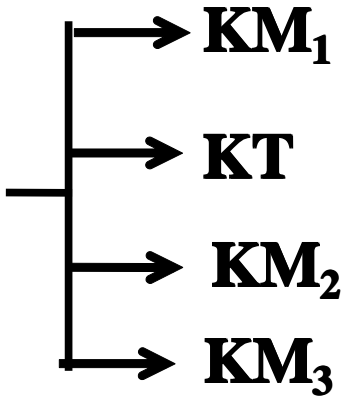
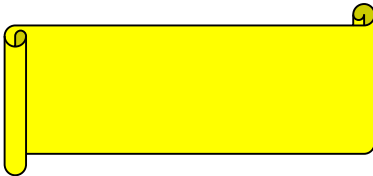
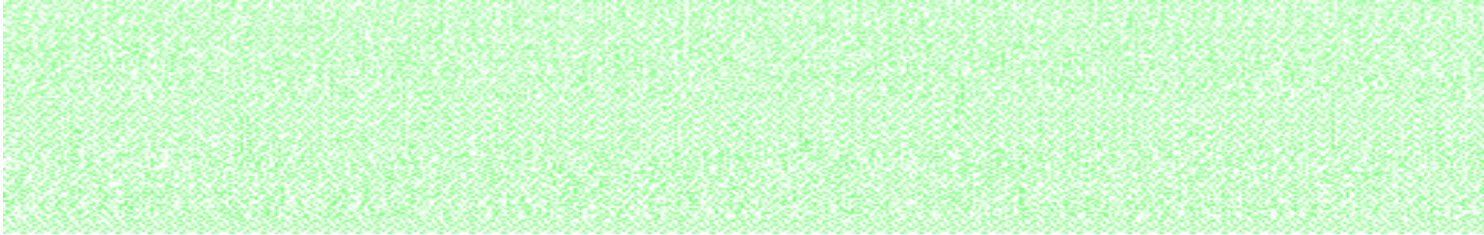

Y

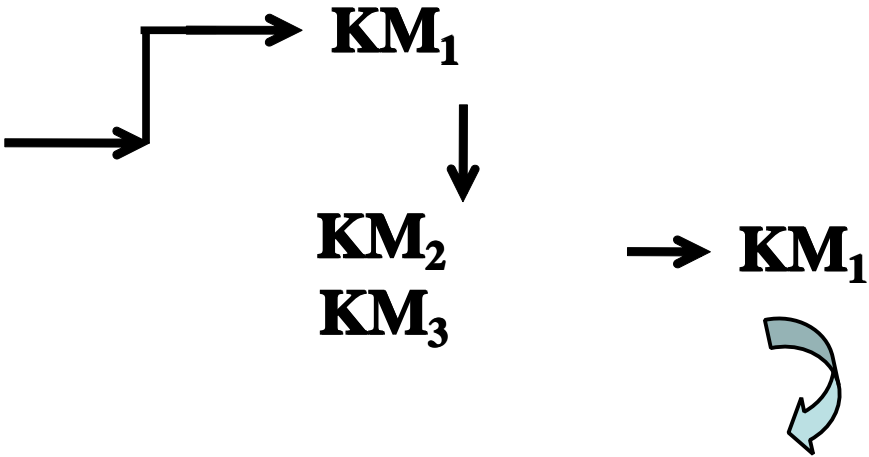

$\Rightarrow \Delta$



8.5

1. M_2

M_1

M_2

$SB_1 \rightarrow M_1$
 $SB_2 \rightarrow M_2$

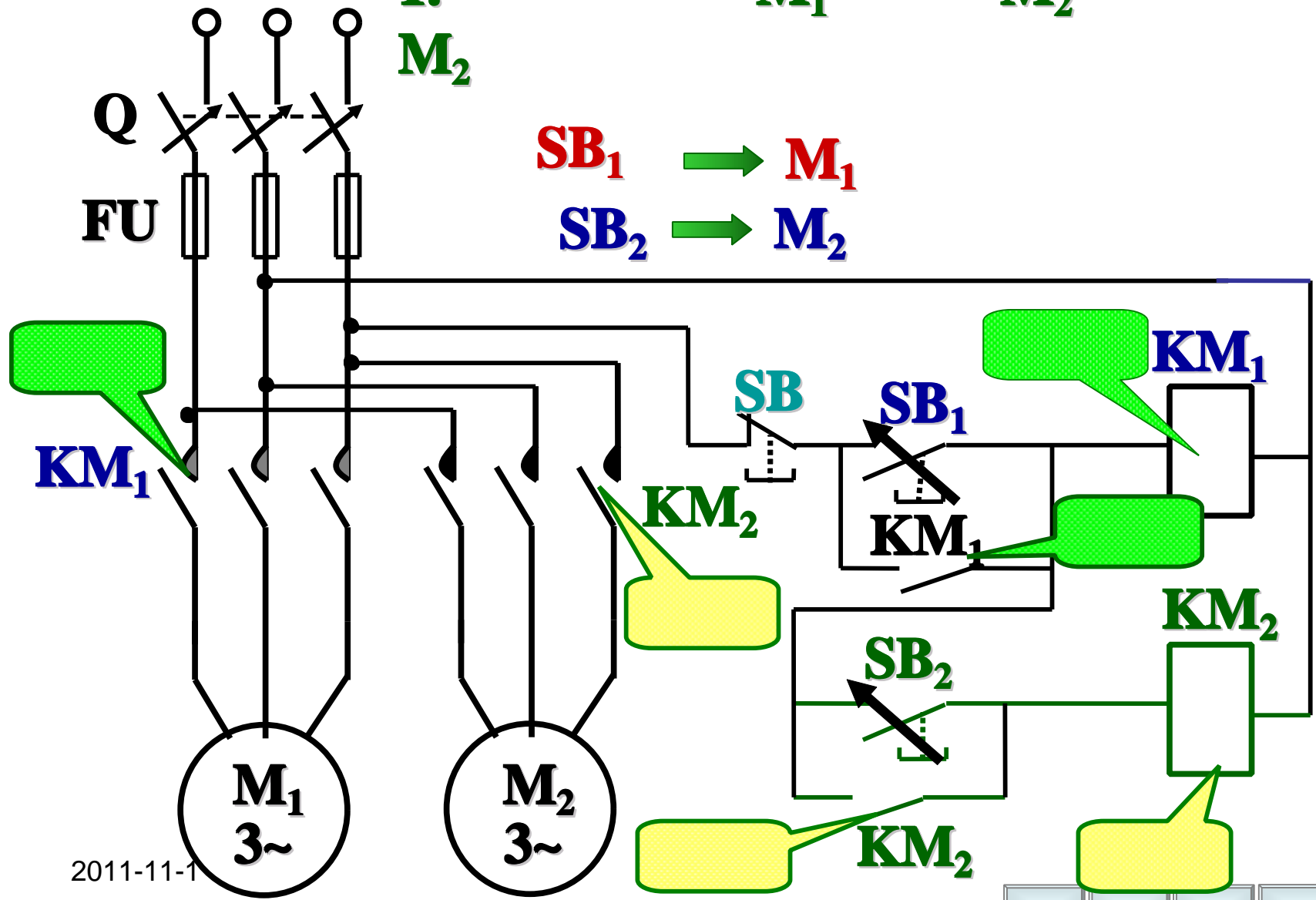

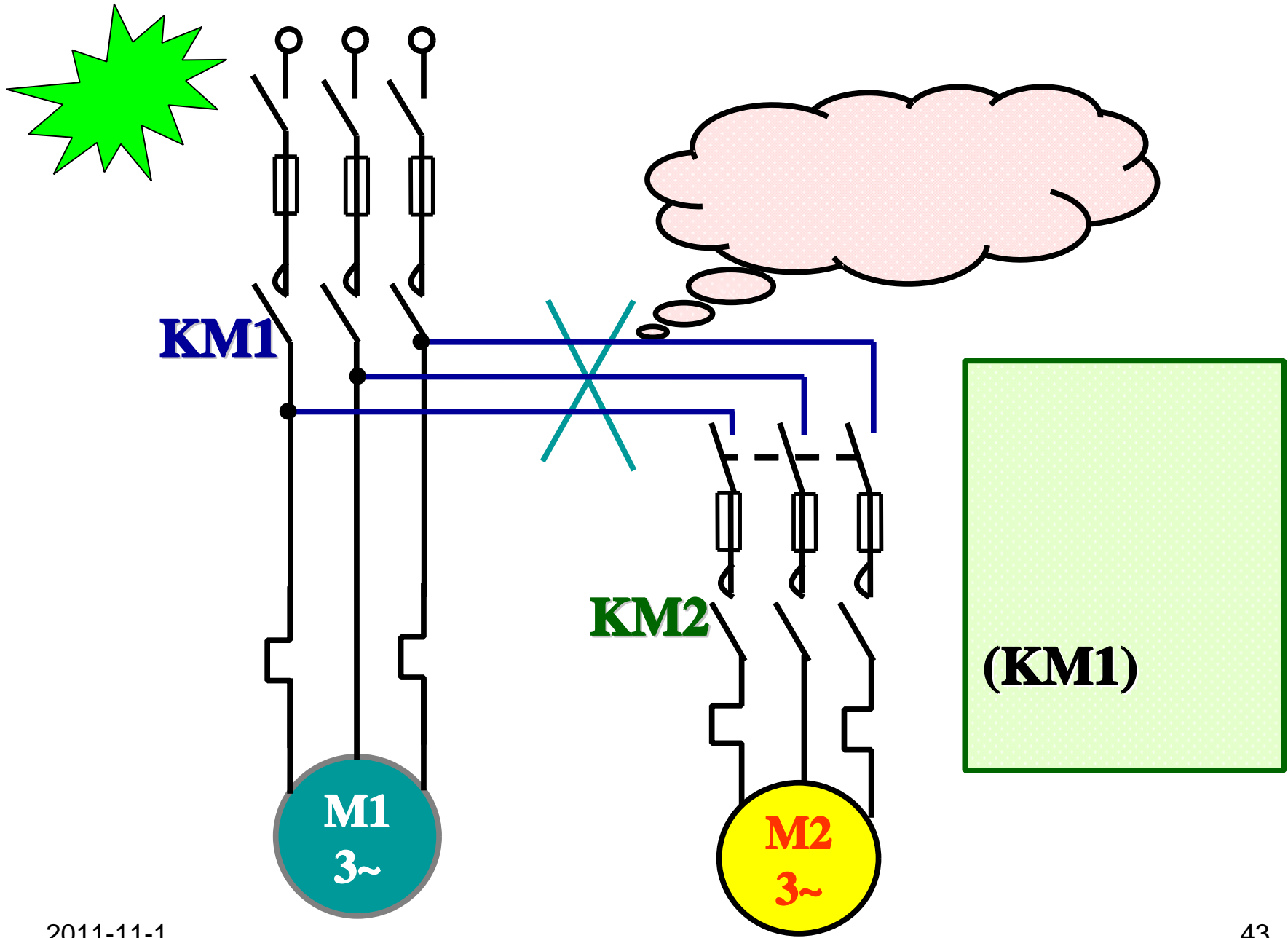

2011-11-1



1

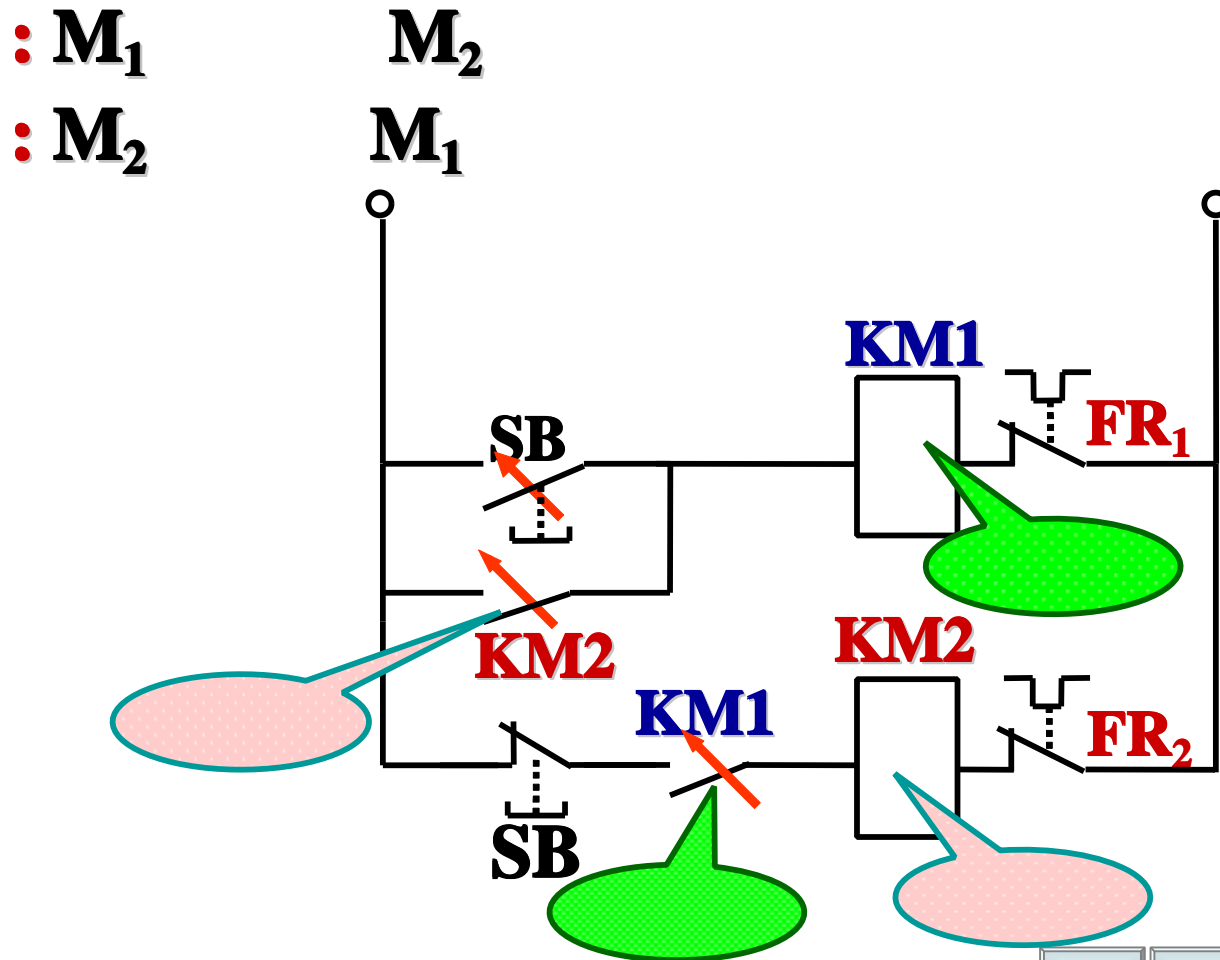

2011-11-1

44



2.

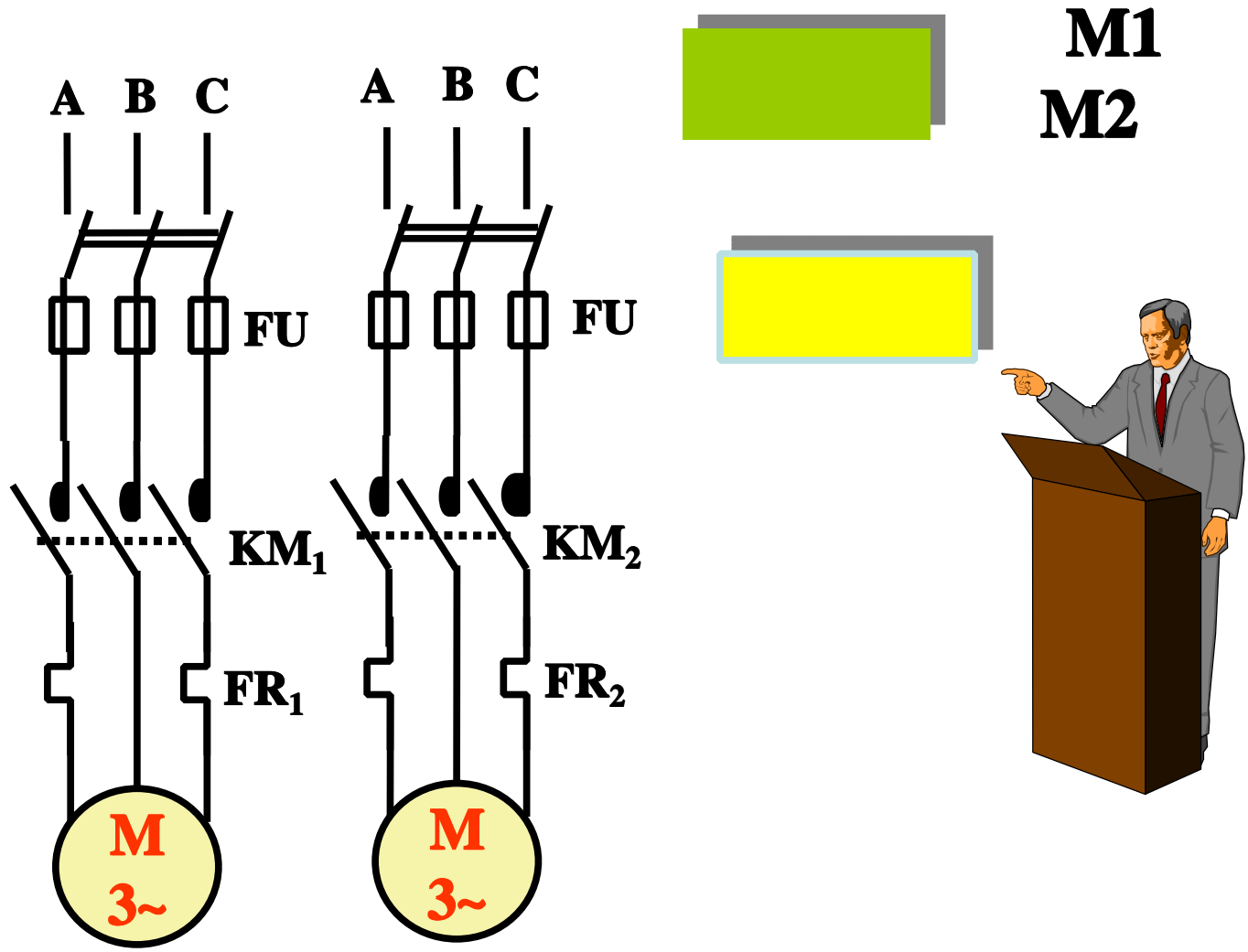

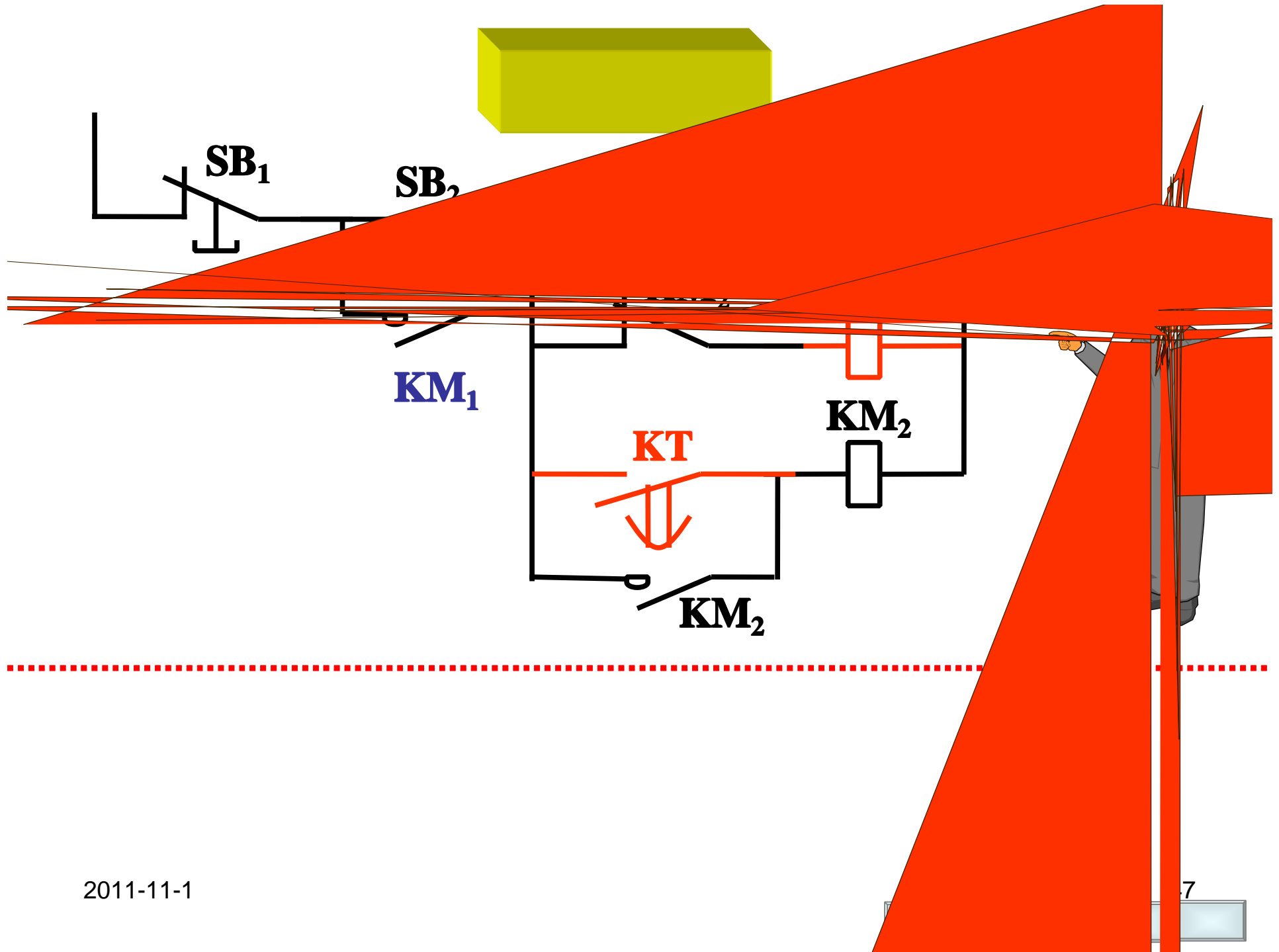

2011-11-1

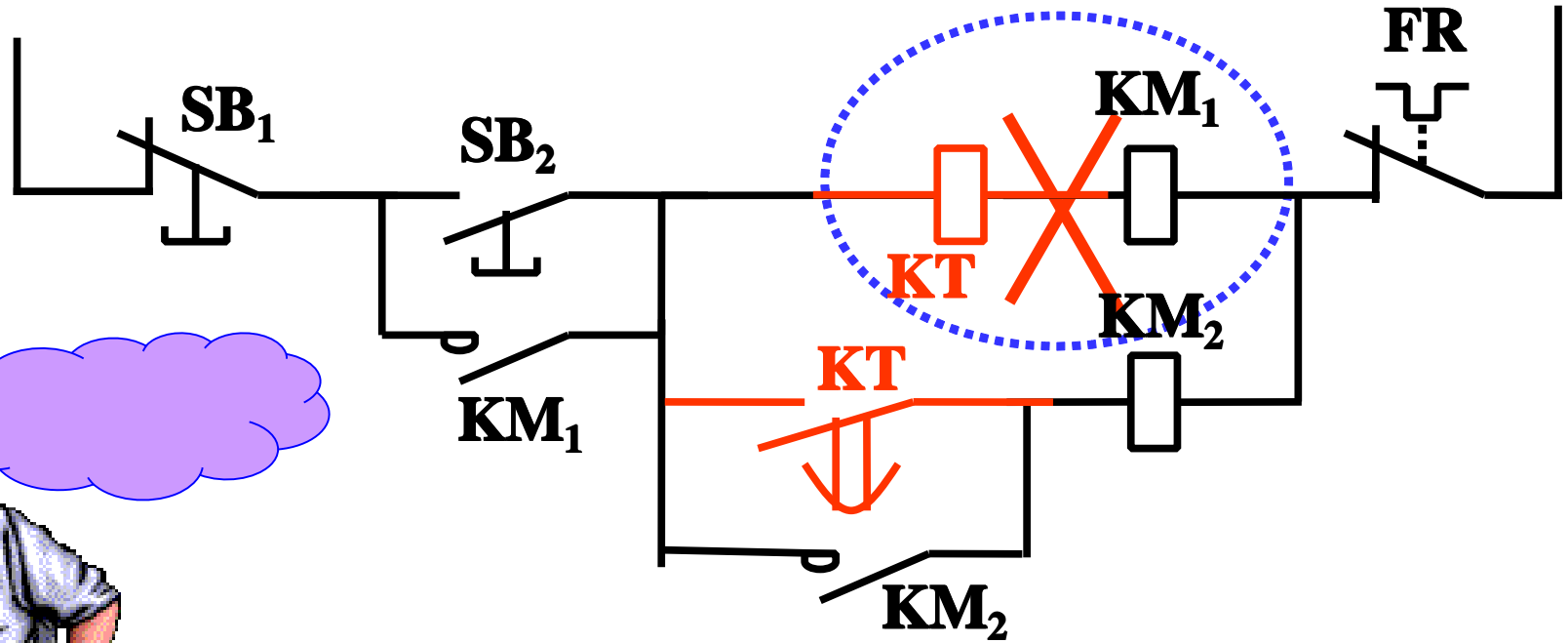
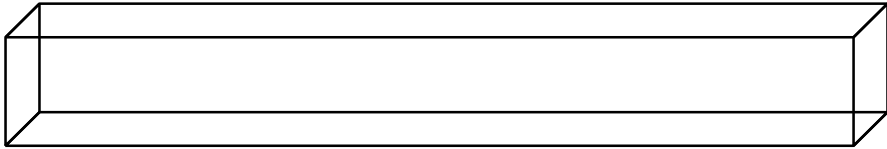

1.

A
B

1
1

A

B
A

2.

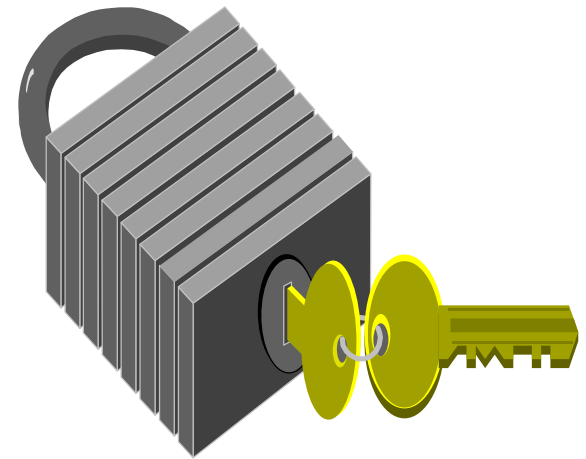

2011-11-1

49



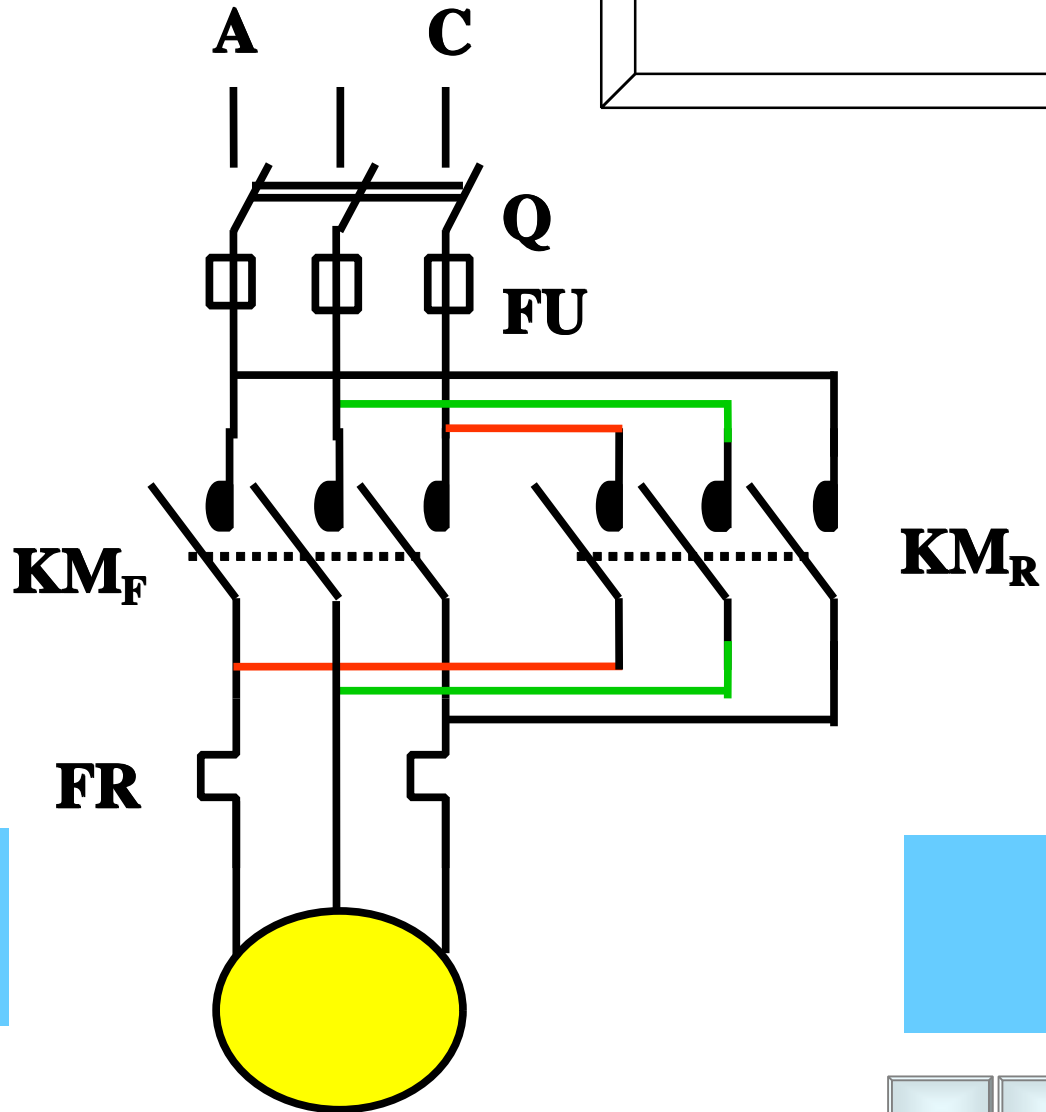

2011-11-1



50

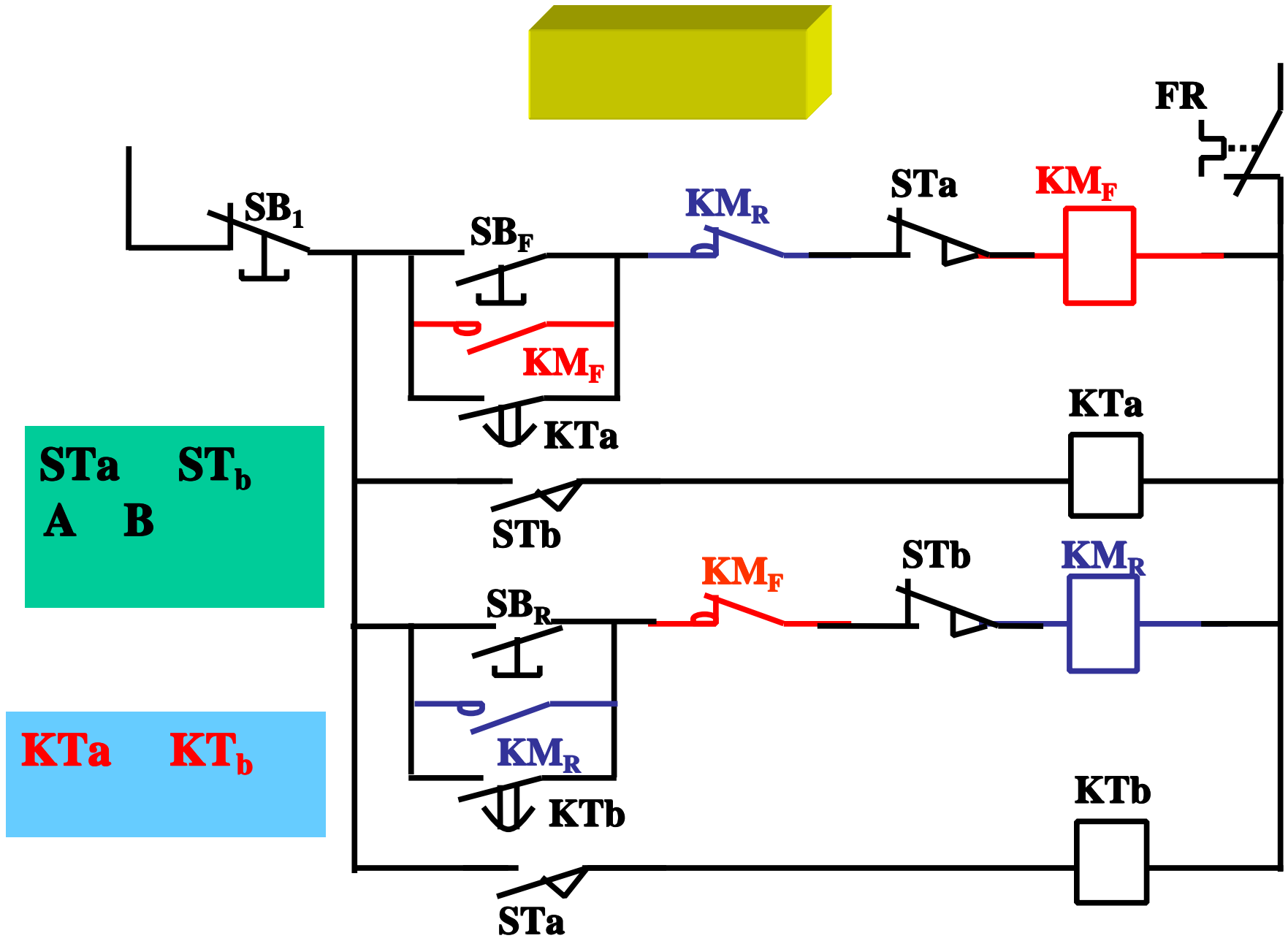

2011-11-1



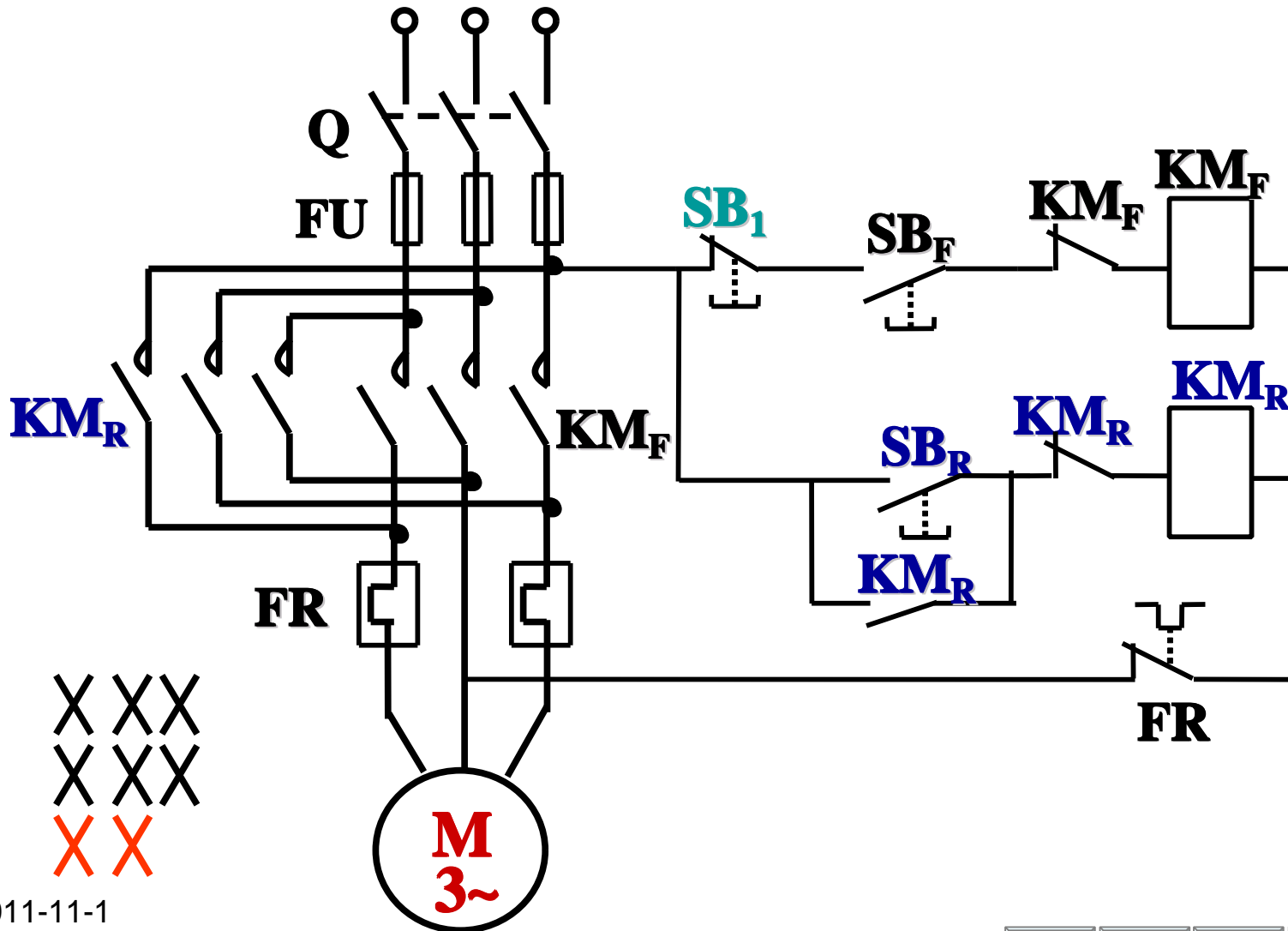

X X X
 X X X
 X X

2011-11-1

52



2011-11-1

53

