

# 7



}

}

}

}





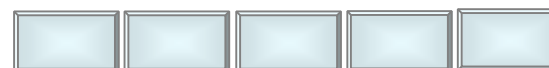
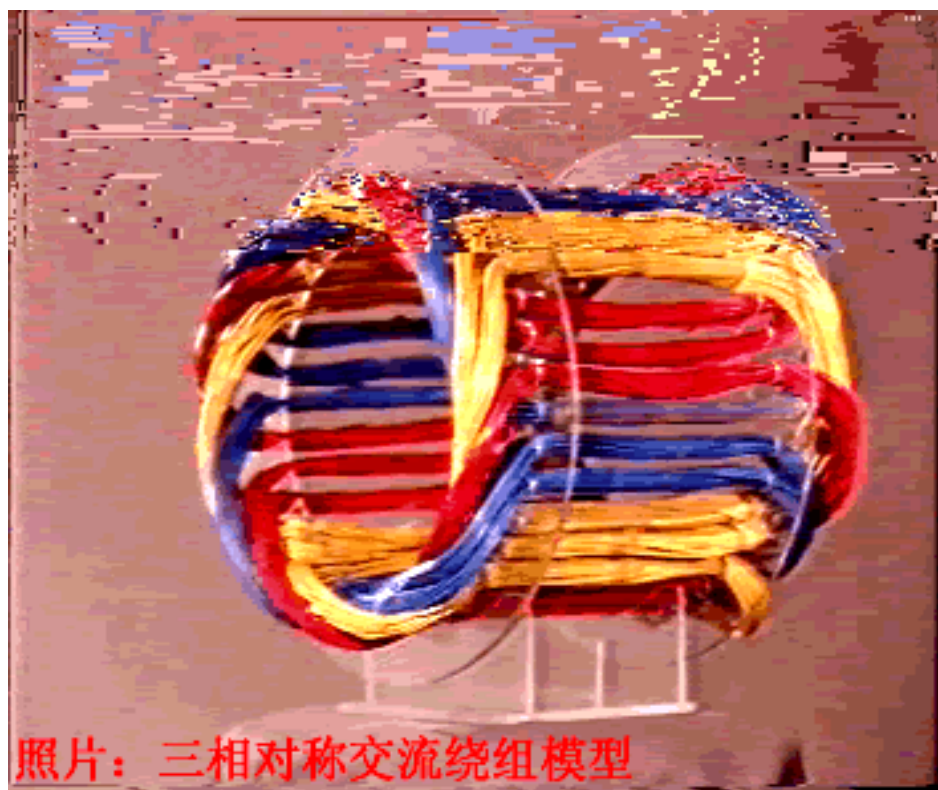

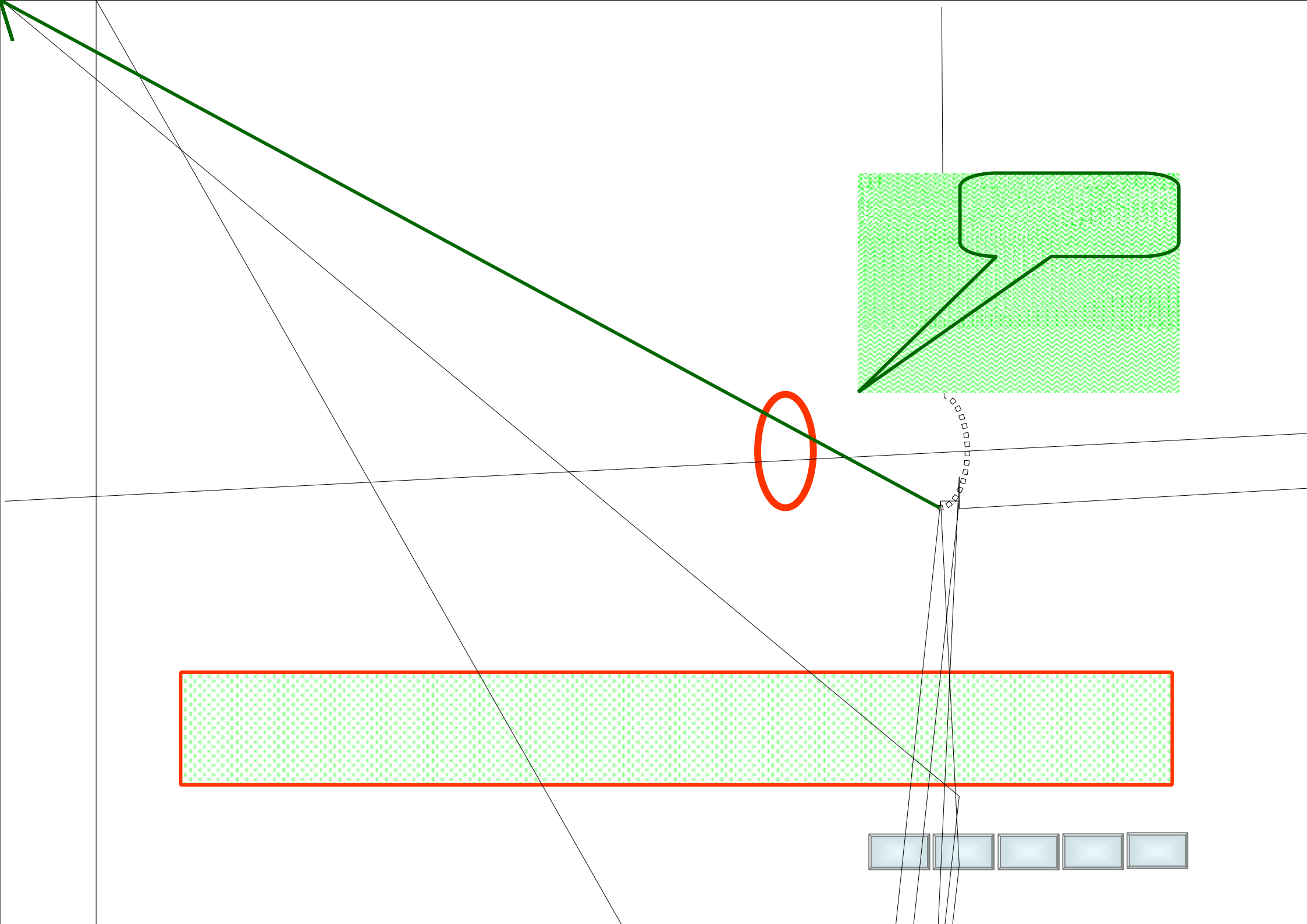

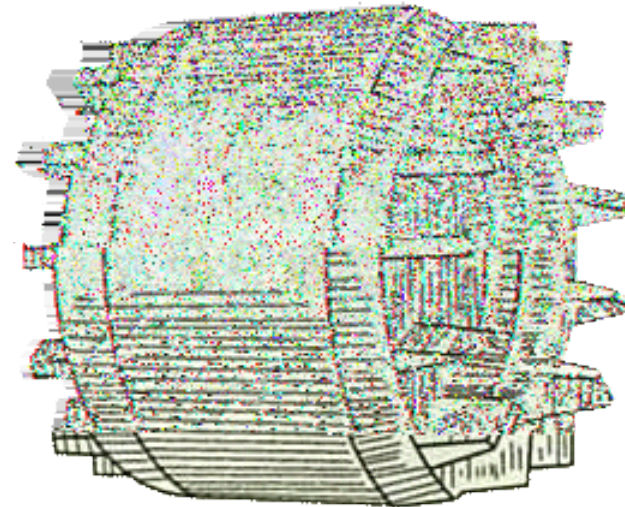
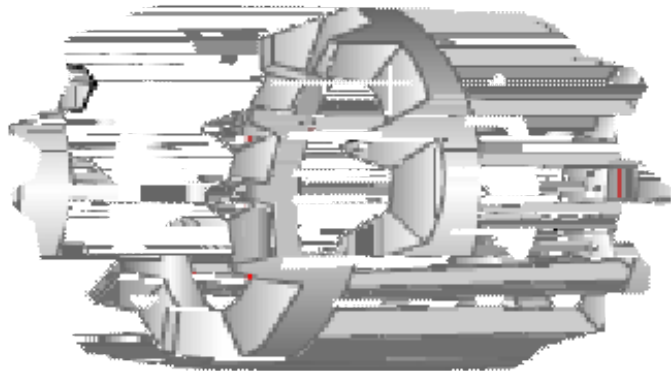
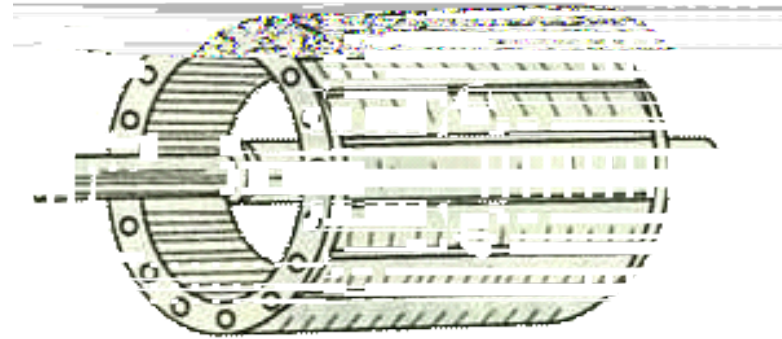
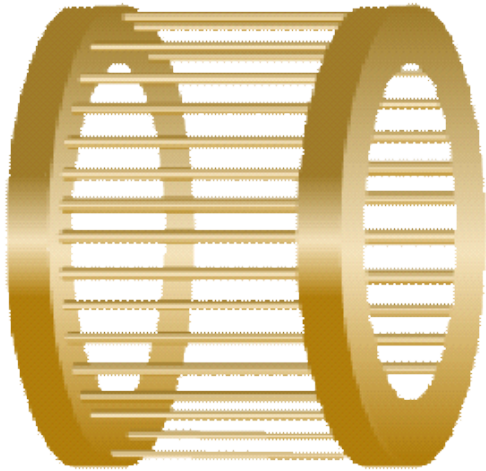



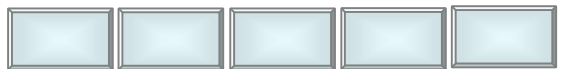
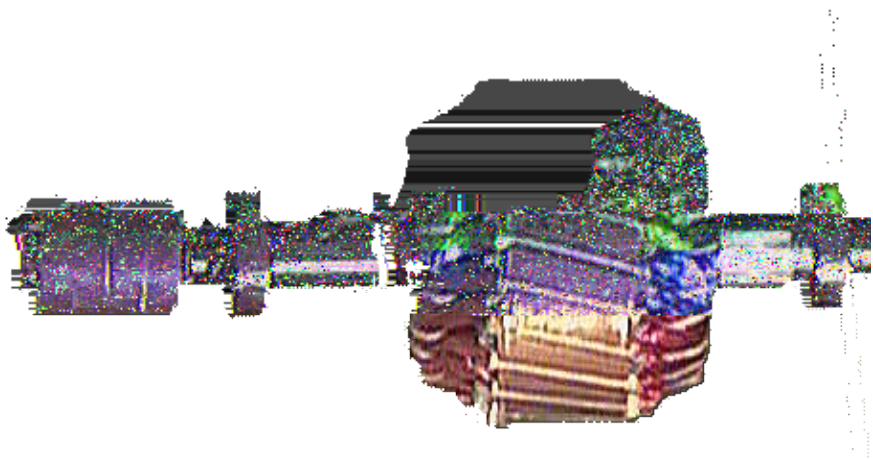
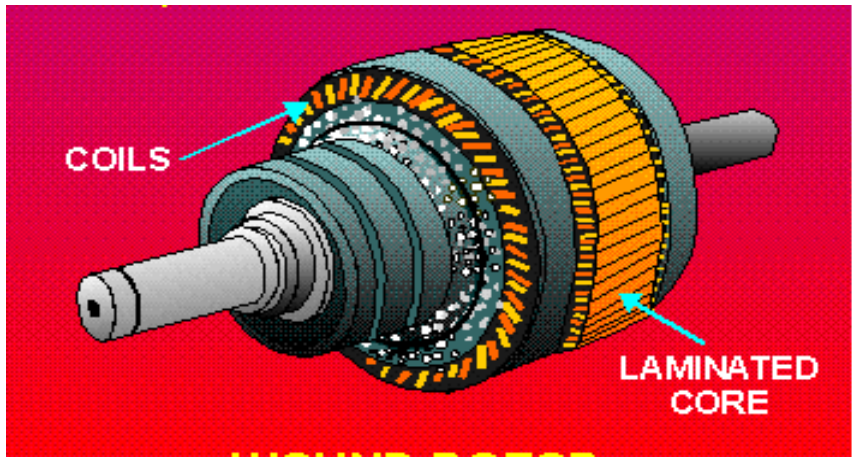
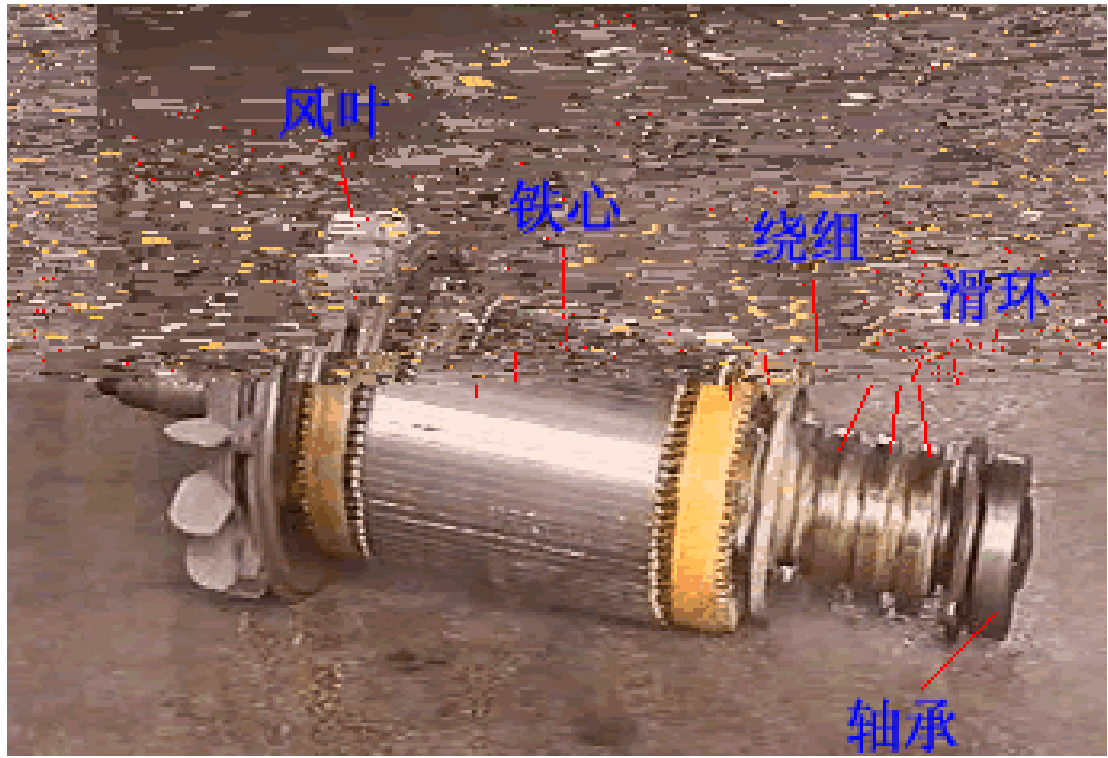



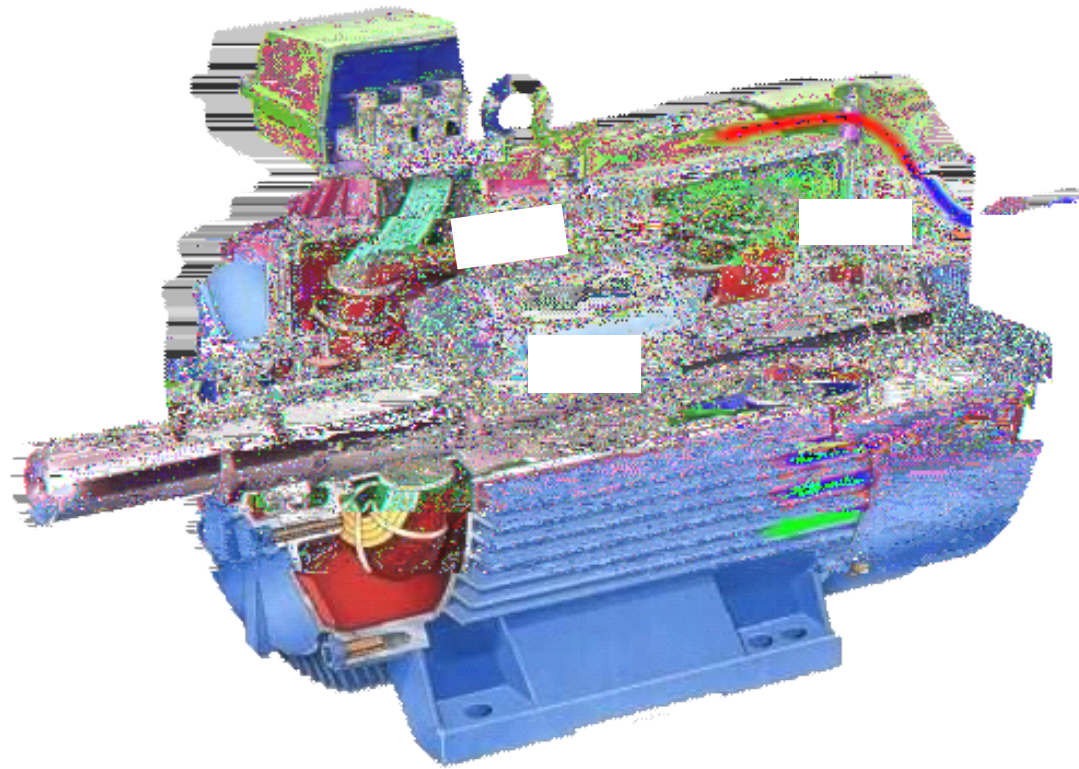

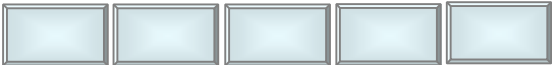

$$\left\{ \begin{array}{l} = I \quad \omega \\ = I \quad (\omega - \circ) \\ = I \quad (\omega + \circ) \end{array} \right.$$

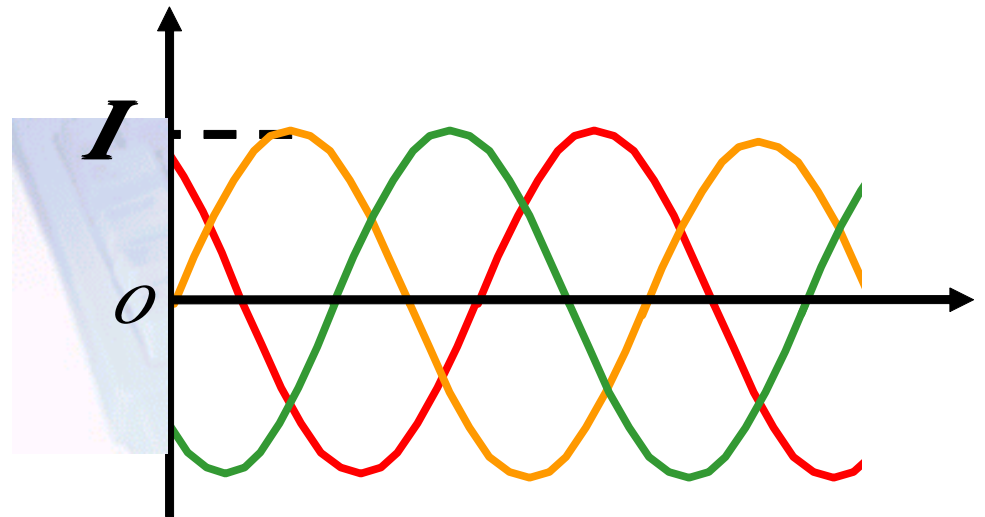
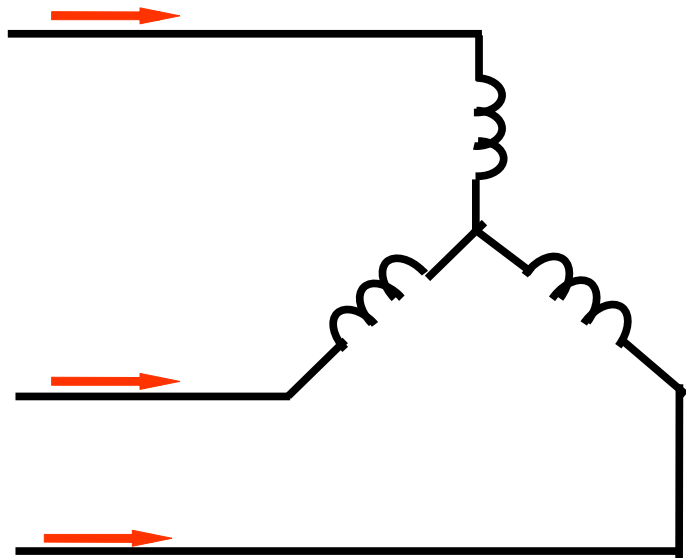

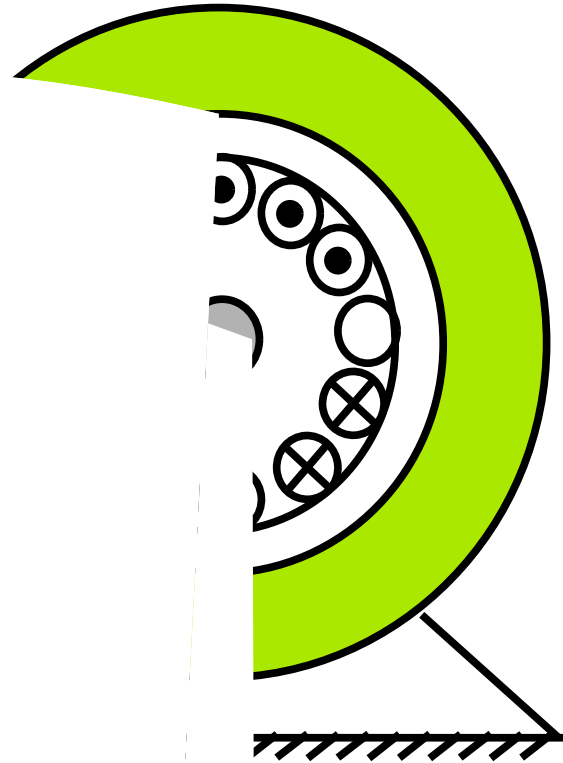

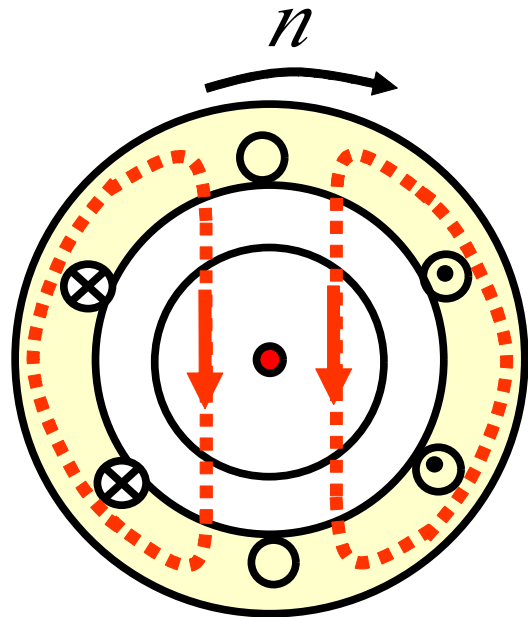
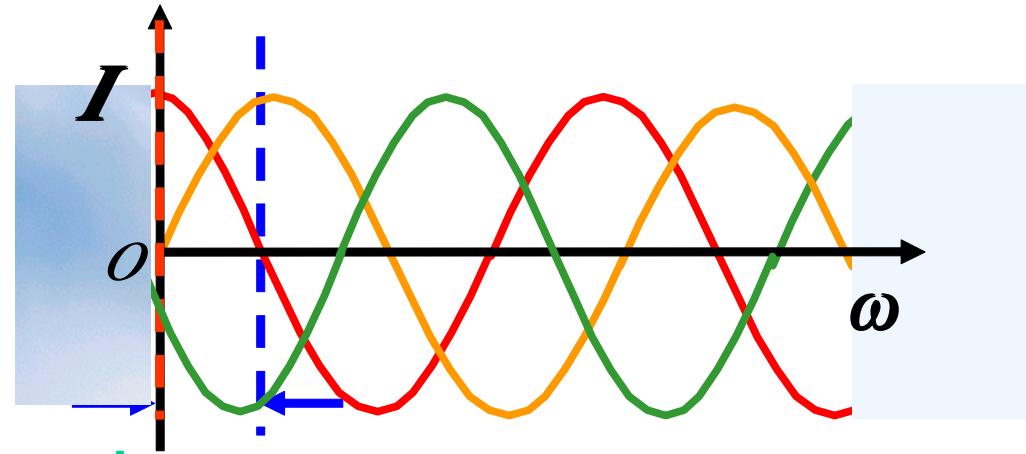

$$\omega =$$

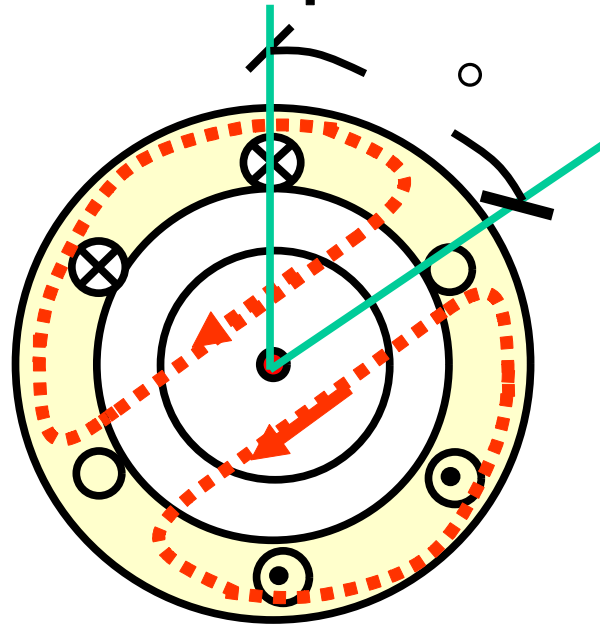

$$\omega = \circ$$

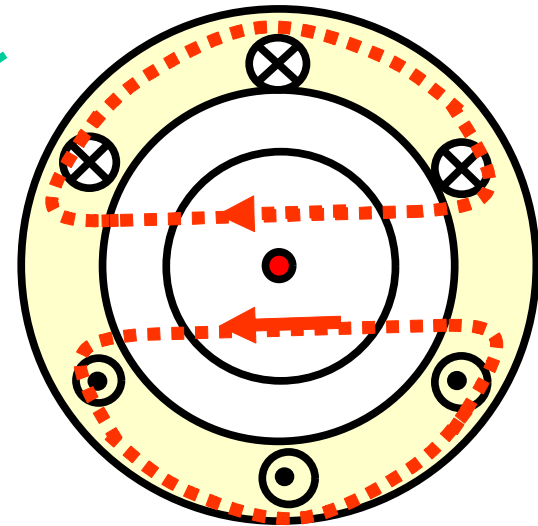

$$\omega = \circ$$



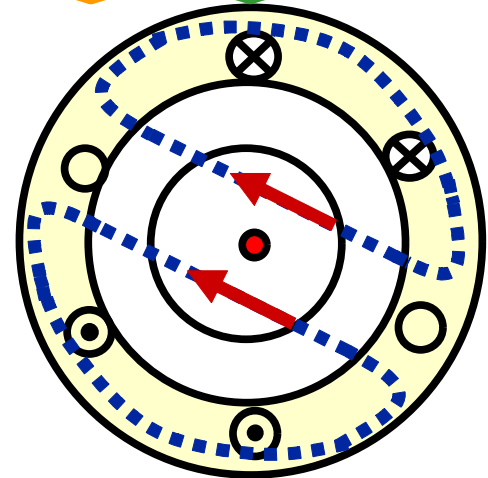
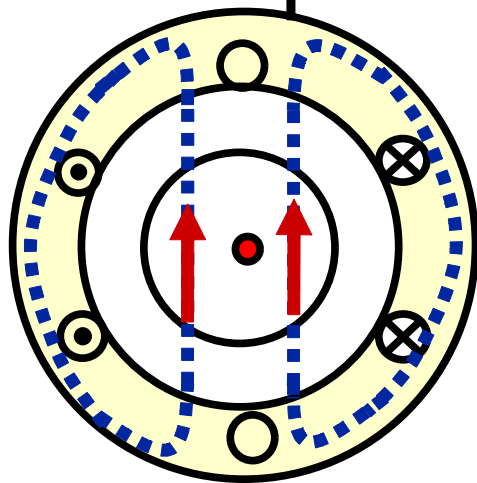
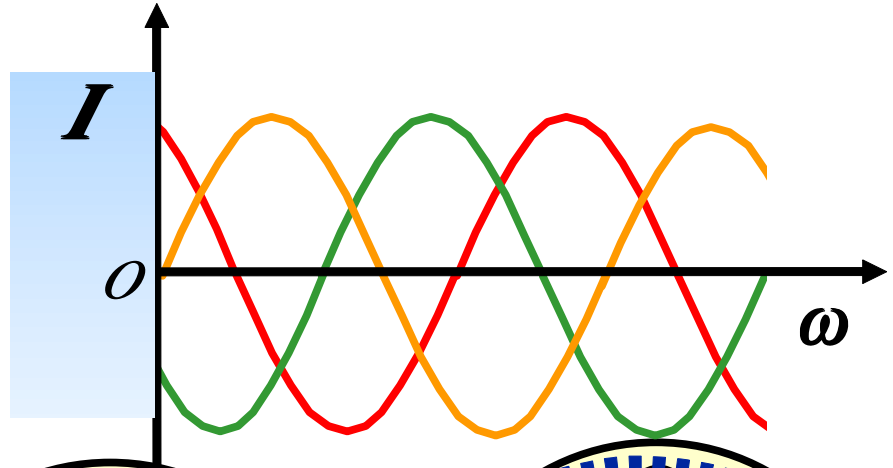
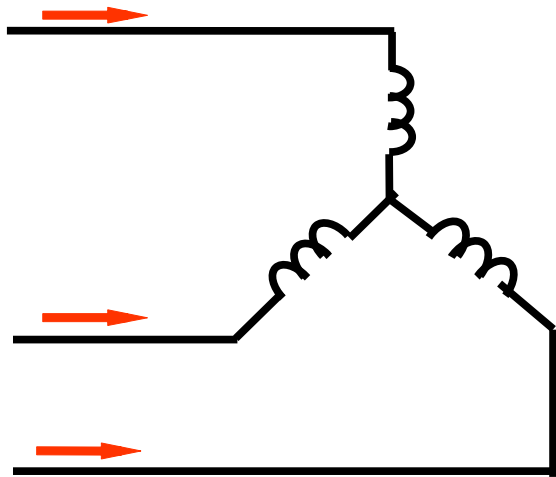

$\omega =$

$\omega = 0$





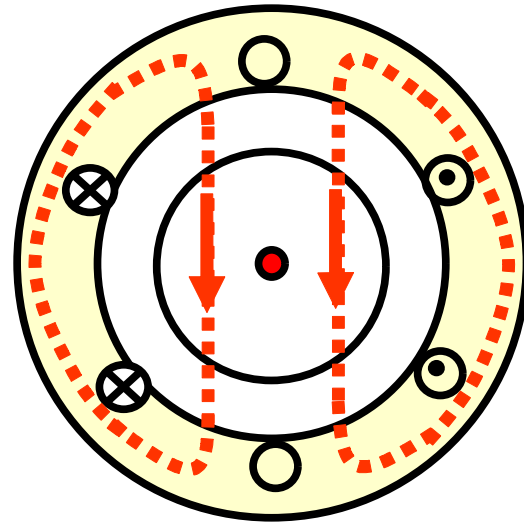
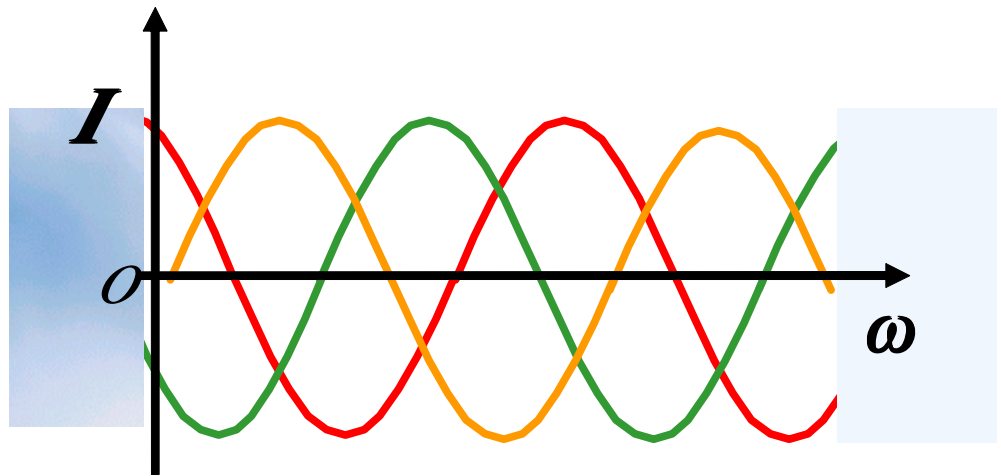
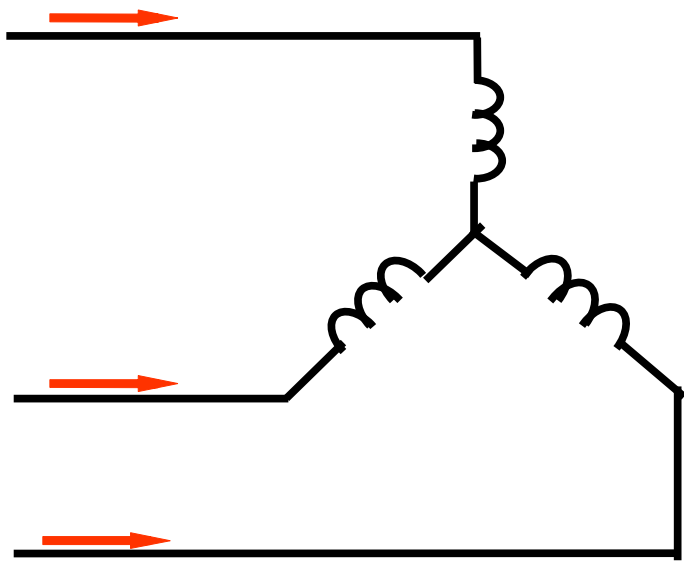

=

$\omega$  =











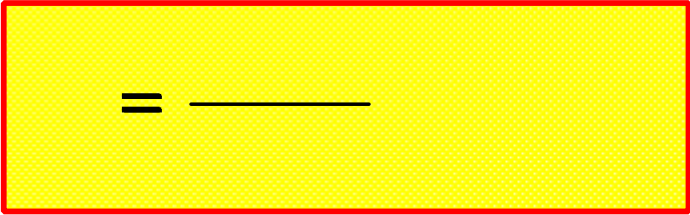

		=
$p =$	o	
$p =$	o	
$p =$	o	
=	o	

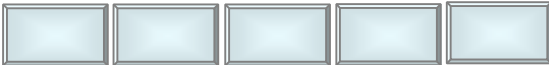
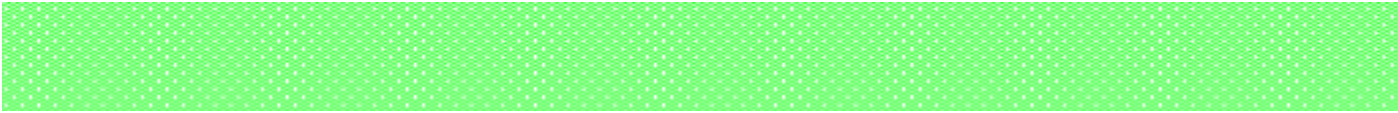



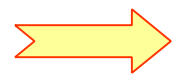
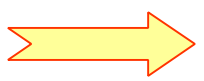
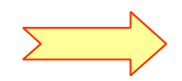
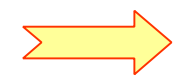

=

$B$

$I$

$B$

$B$

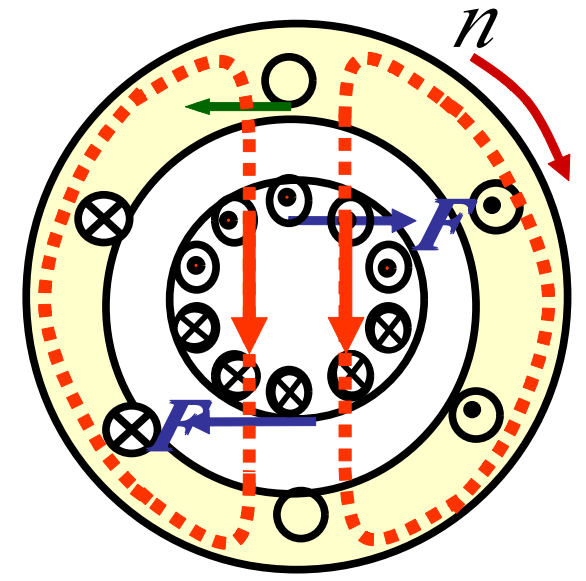



||

<

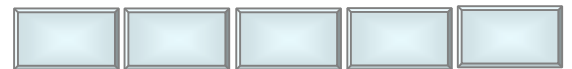
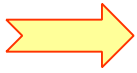
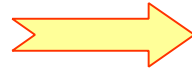

$$= \left( \frac{-}{-} \right) \times$$

$$= -$$

$$s =$$

$$= \frac{-}{-} \times$$

$$= \frac{-}{-} \times$$

=



$$\begin{array}{ccc}
 & \Phi & \rightarrow \\
 \approx E & & N \Phi \\
 E & & N \Phi \\
 E & E &
 \end{array}$$

$$\Phi_m \approx \frac{U}{f N}$$

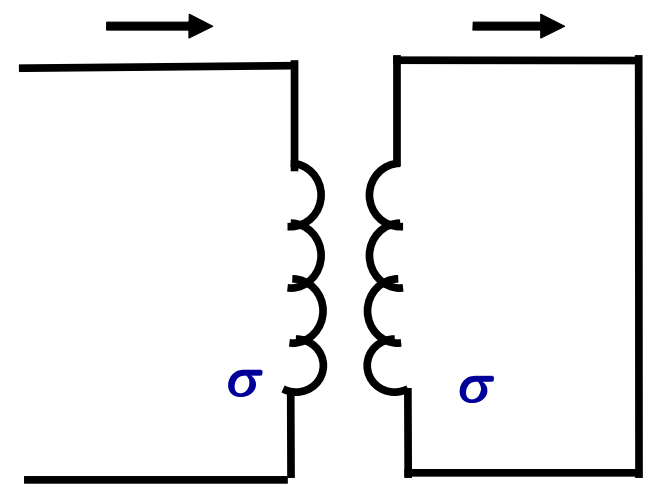

1

$\Phi$

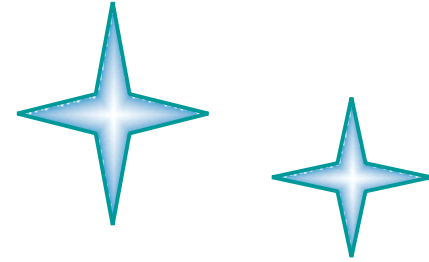

$\approx E$

$N\Phi$

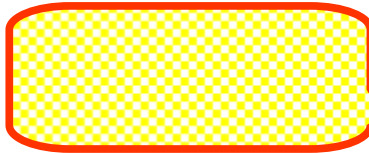

$$\Phi \approx \frac{\cdot}{N}$$



$$f = \frac{\rho n}{\cdot}$$



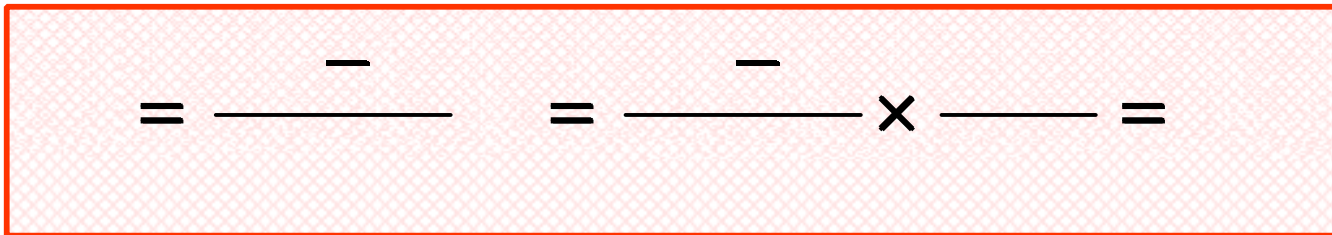
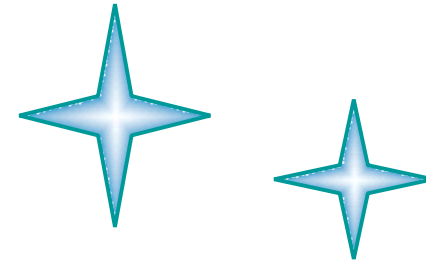



$E$   $N\Phi$   $E$

$N\Phi$   $E$   $E$

$E$   $N\Phi$

$E$   $E$

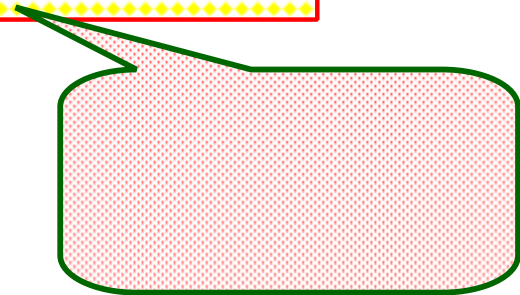
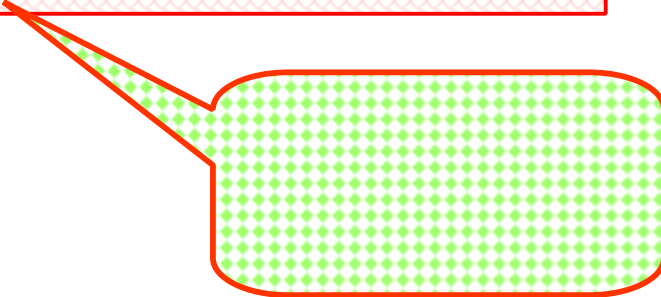

$$= \pi L = \pi L$$

$\pi L_\sigma$

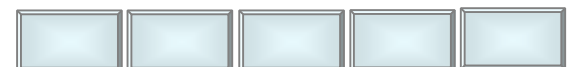

$$I = \frac{I E}{\sqrt{+ E}}$$

$$= \frac{E}{\sqrt{+}}$$

$$\left\{ \begin{aligned} &= \rightarrow I = = \\ &= \rightarrow I = \frac{E}{\sqrt{+}} \end{aligned} \right.$$

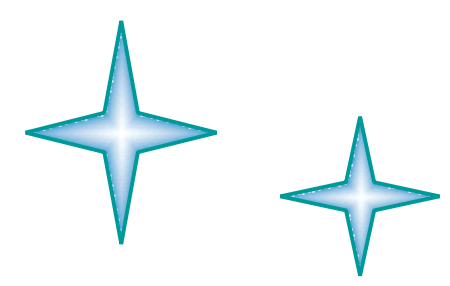

$$\psi = \frac{\psi}{\sqrt{+}}$$

$$= \frac{\psi}{\sqrt{+}}$$

$$\left\{ \begin{aligned} &>> \\ &\psi \approx \\ &<< \\ &\psi \propto - \end{aligned} \right.$$

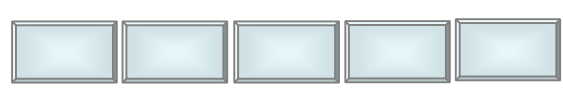

$$I = \frac{E}{\sqrt{\psi}} = \frac{E}{\sqrt{\psi}}$$

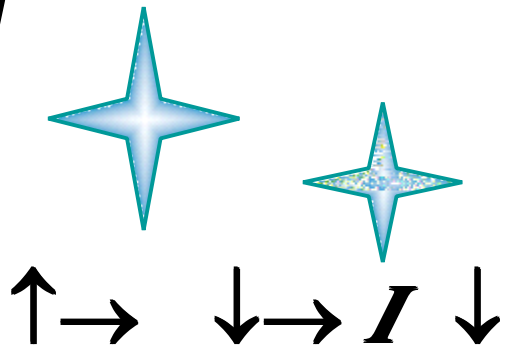

$$\psi = \frac{I}{\sqrt{\psi}}$$

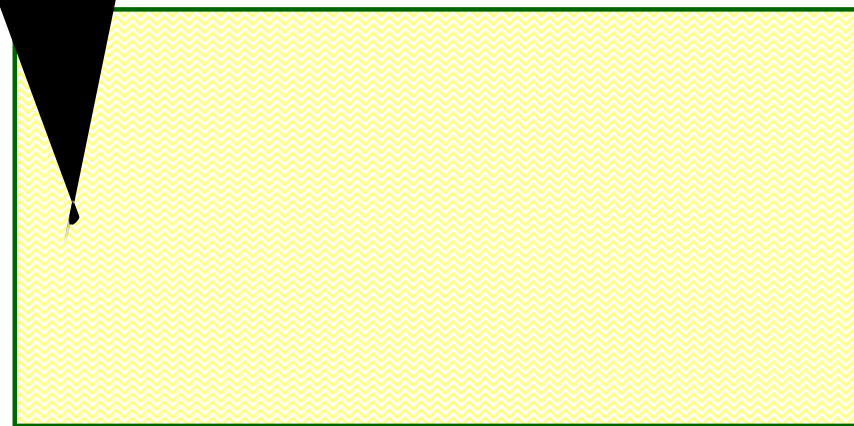
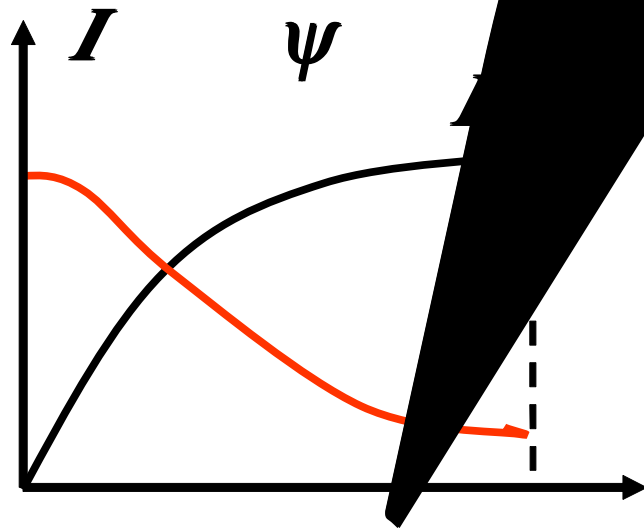
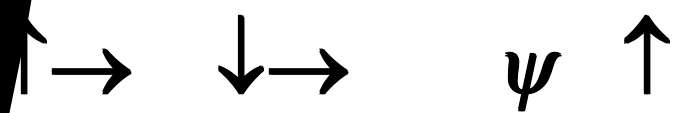

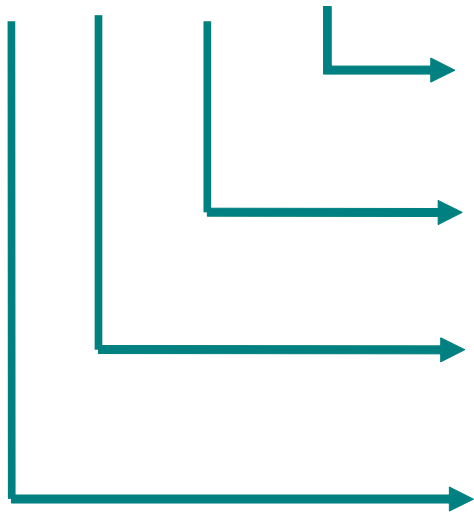

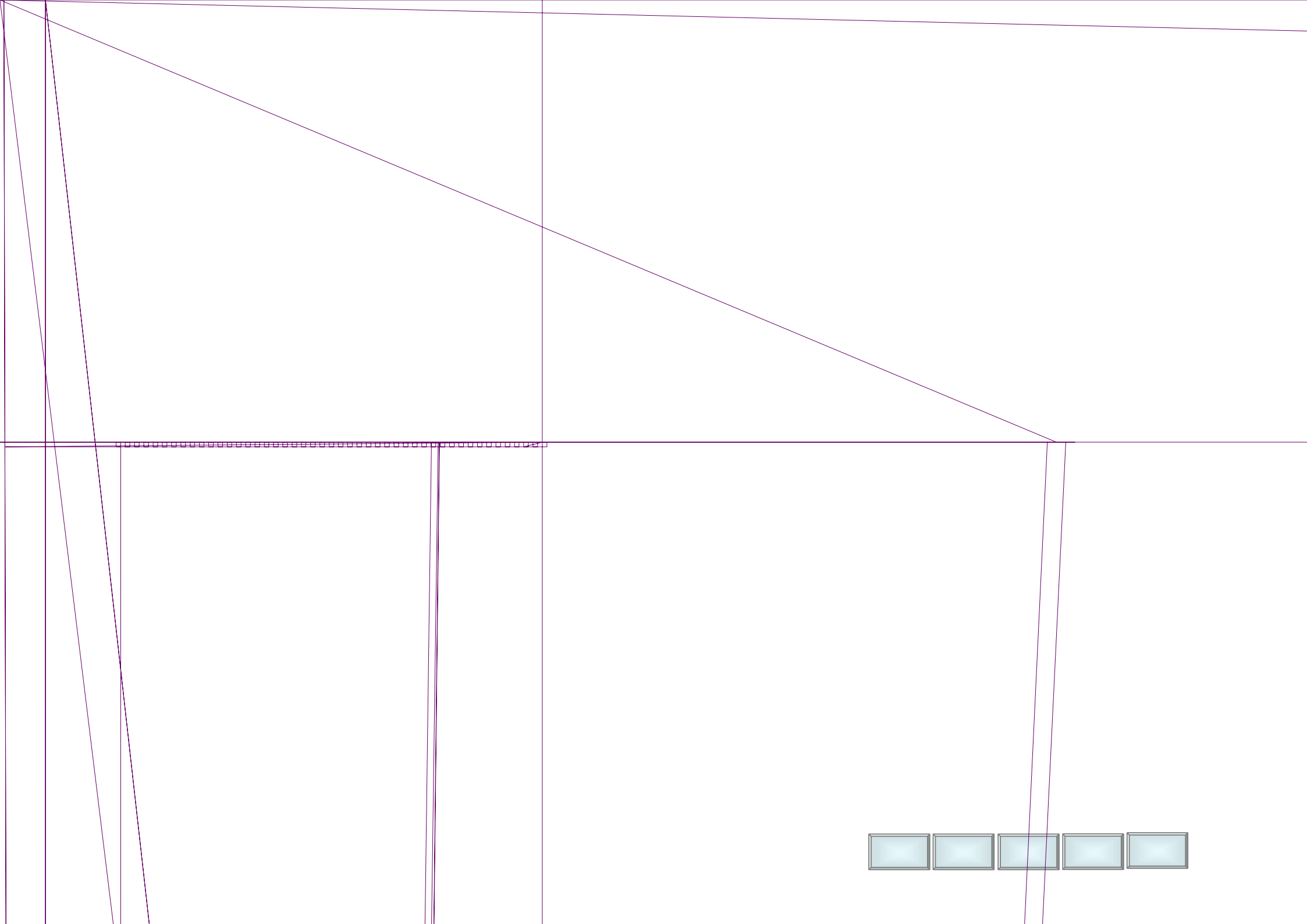

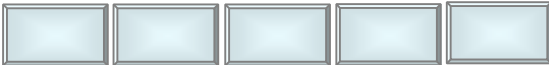
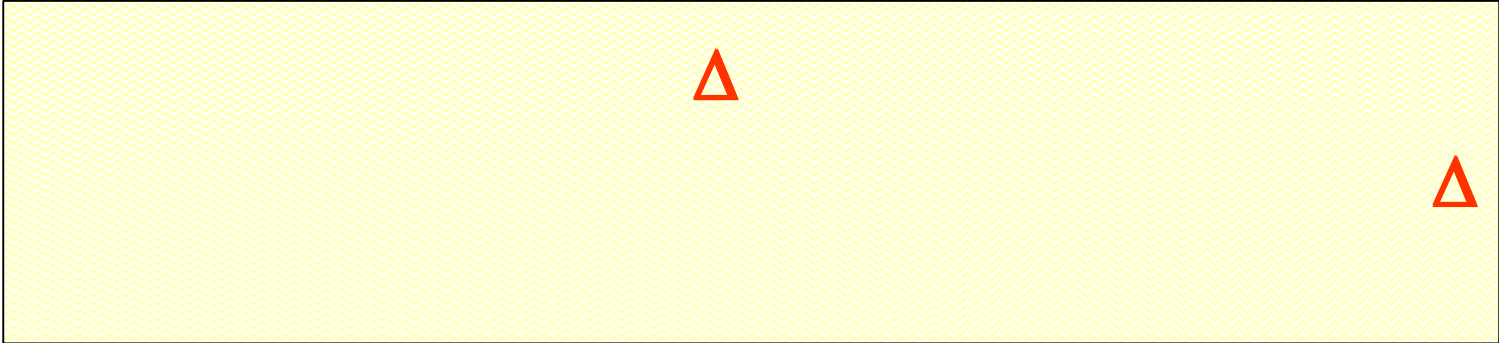



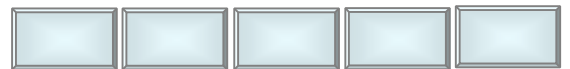
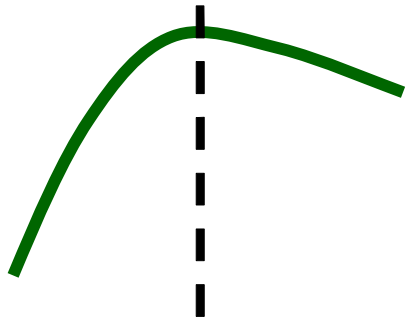





$$F = B$$

$$\propto I \psi$$

$$= K I \psi$$

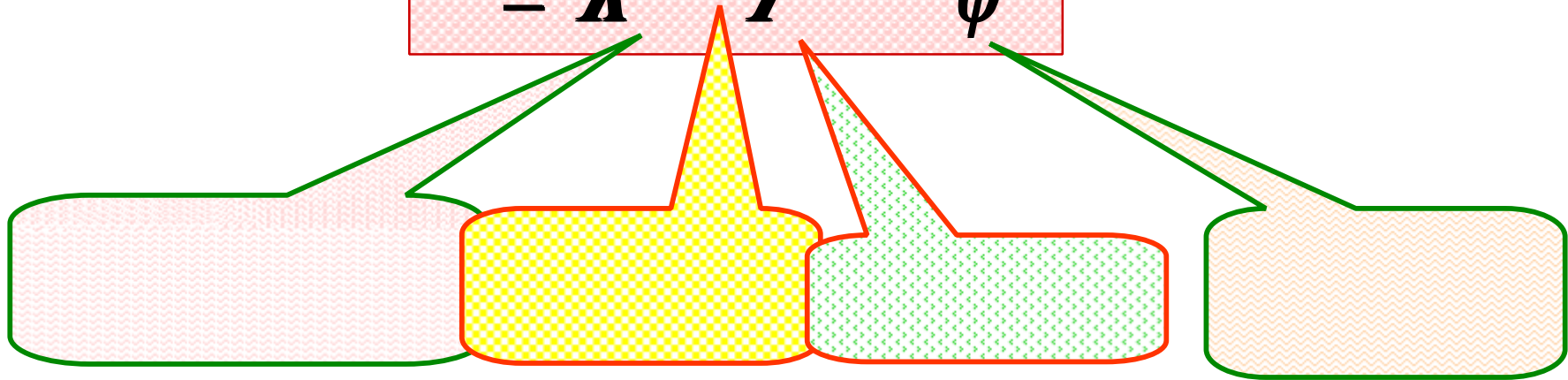

$$= K I \psi$$

$$\left\{ \begin{array}{l} I = \frac{E}{\sqrt{\quad + \quad}} \\ \psi = \frac{\quad}{\sqrt{\quad + \quad}} \\ U = f N \end{array} \right.$$

$$= K \frac{\quad}{\quad + \quad} \cdot$$



$$= K \frac{\quad}{+ \quad} \cdot$$



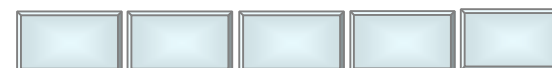
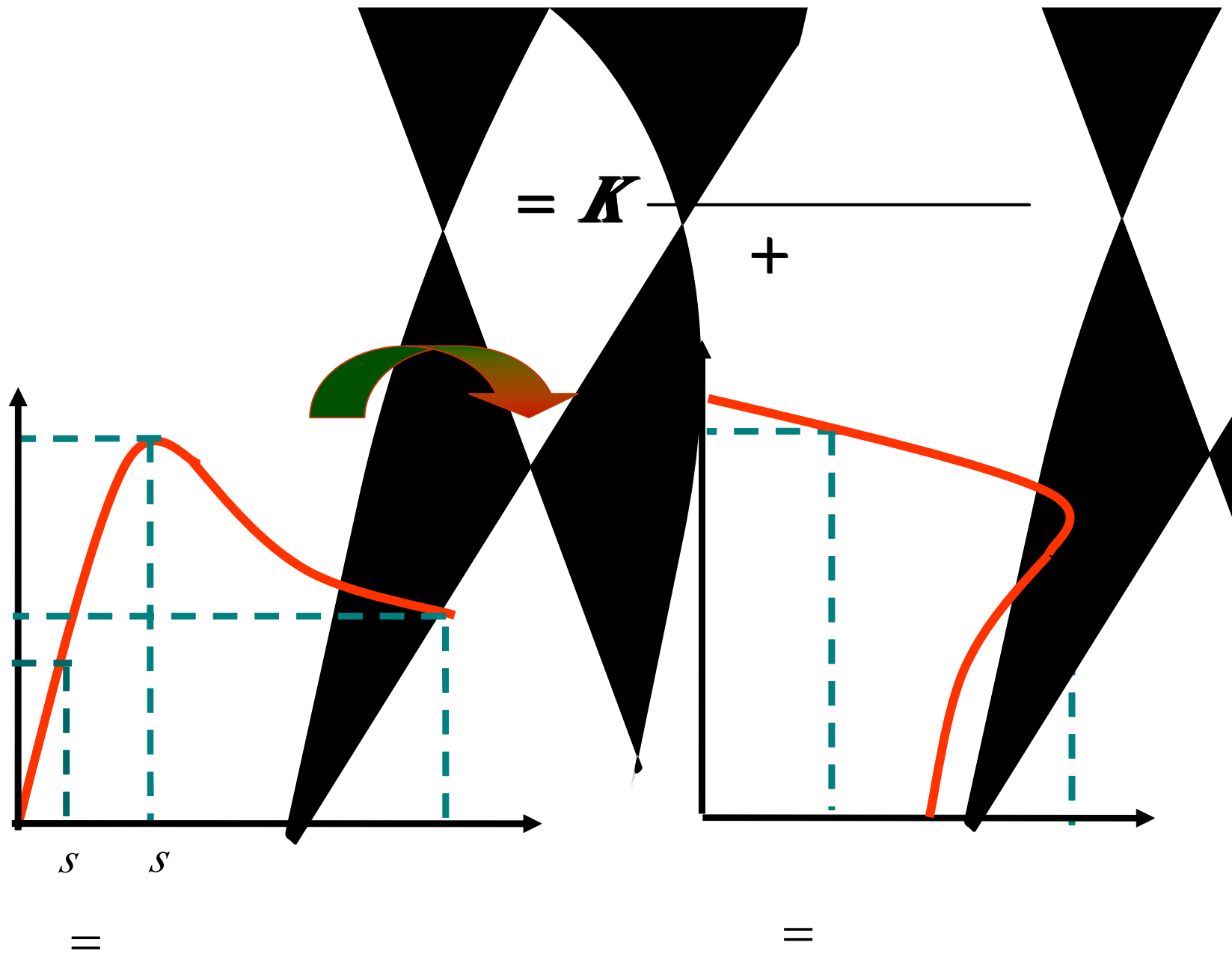

= \_\_\_\_\_ = \_\_\_\_\_

= \_\_\_\_\_

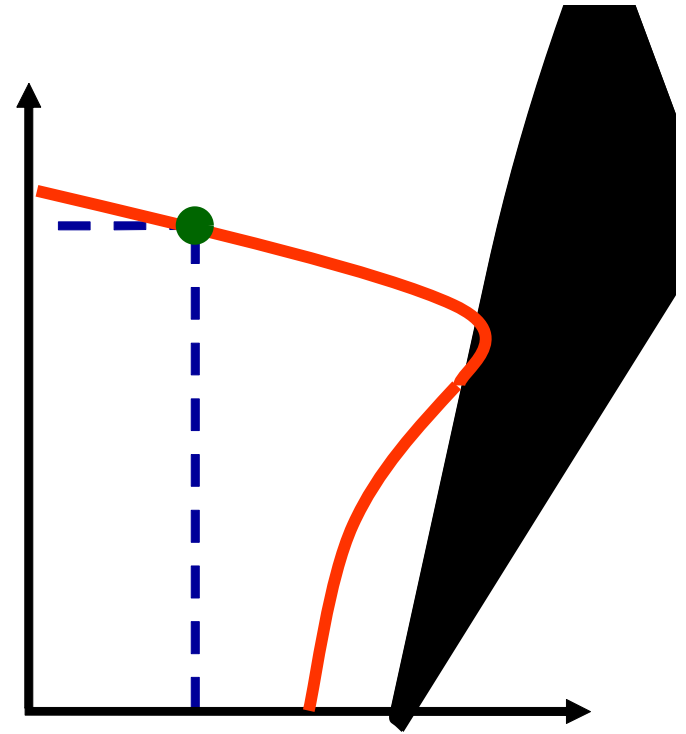

= \_\_\_\_\_ = \_\_\_\_\_ = \_\_\_\_\_



$$= K \frac{\dots}{\dots} + \dots$$

$$\dots = \dots$$

$$= \dots = \dots$$

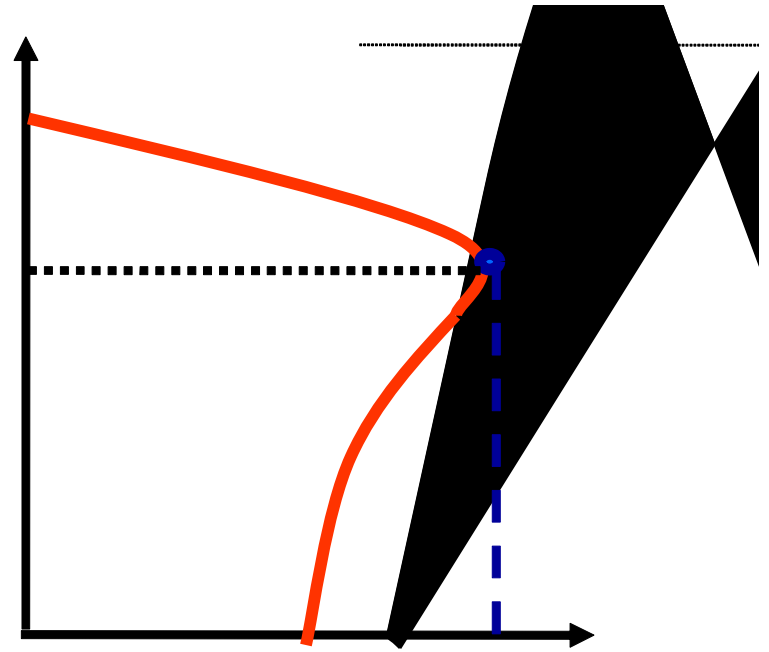
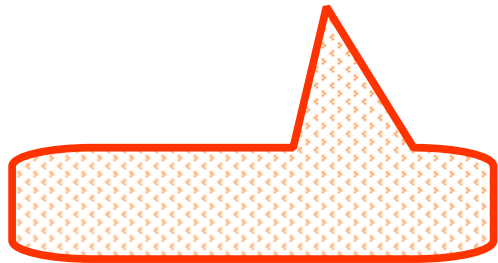

$$= K \frac{\dots}{\dots}$$



$$= \mathbf{K} \text{ —————}$$

$\downarrow \rightarrow$        $\downarrow \downarrow$

$\infty$

$\uparrow \rightarrow$      $\uparrow \rightarrow$

,

$$\lambda = \text{—————} \downarrow$$

$$\lambda =$$

$$\Rightarrow \mathbf{I} \uparrow \Rightarrow \mathbf{I} \uparrow \Rightarrow$$





$$= \mathbf{K} \frac{\quad}{+}$$

$$= \mathbf{K} \frac{\quad}{+}$$

$$\propto \begin{matrix} \downarrow \rightarrow & \downarrow \downarrow \end{matrix}$$

$$\begin{matrix} \uparrow \rightarrow & \uparrow \end{matrix}$$

,

$$\mathbf{K} = \text{---}$$

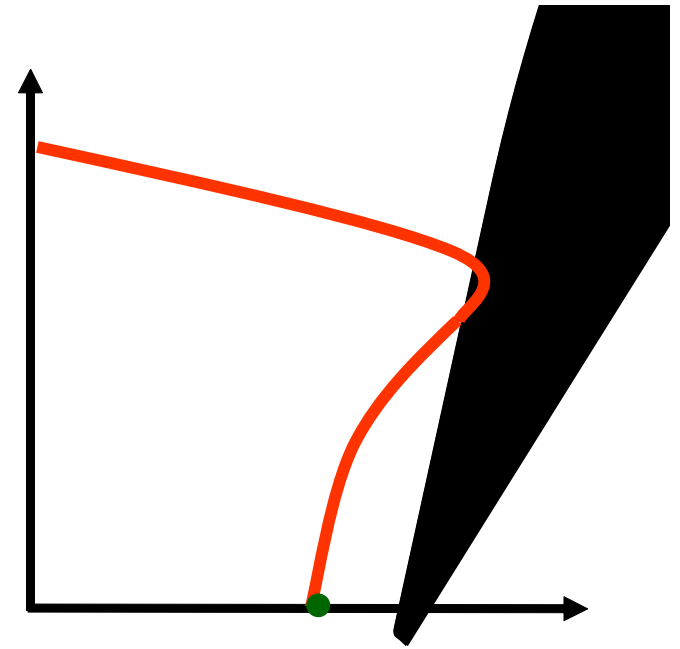

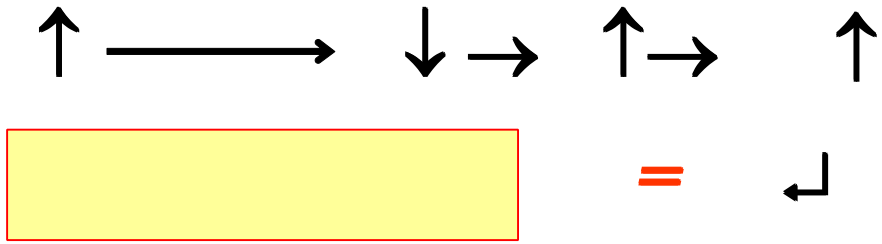

$\downarrow \quad \uparrow \rightarrow E \quad I \uparrow \rightarrow I \uparrow$

$\rightarrow$

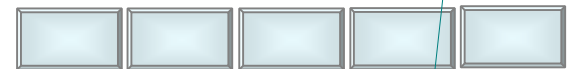
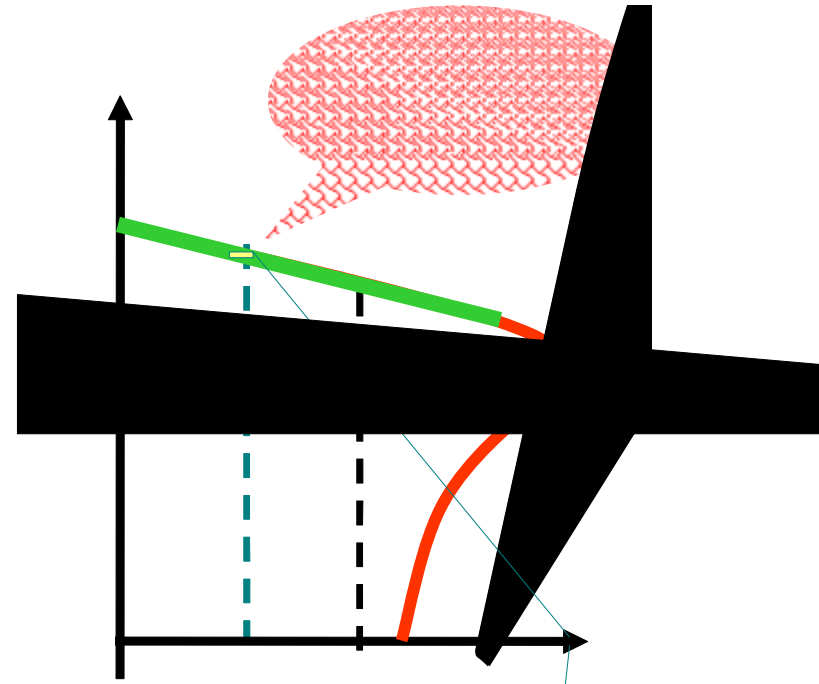



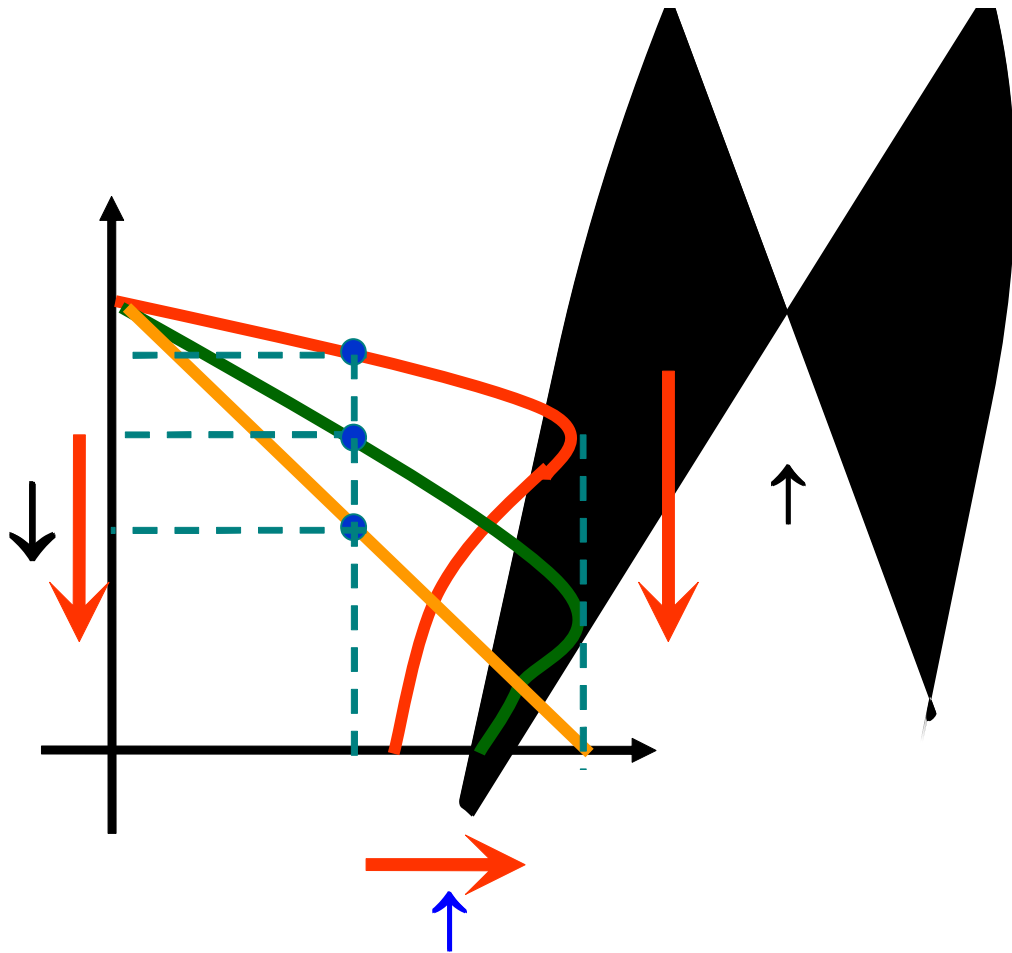

$$= \text{---}$$

$$= K \text{---}$$

$$= K \text{---} +$$



=

=

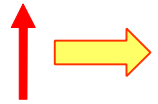

{



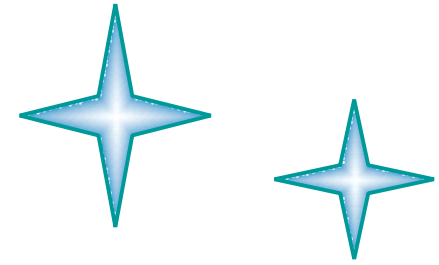

}

Δ



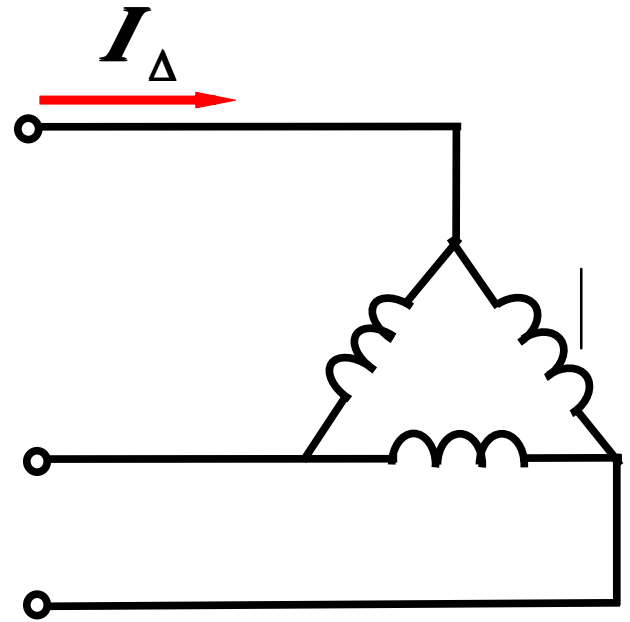
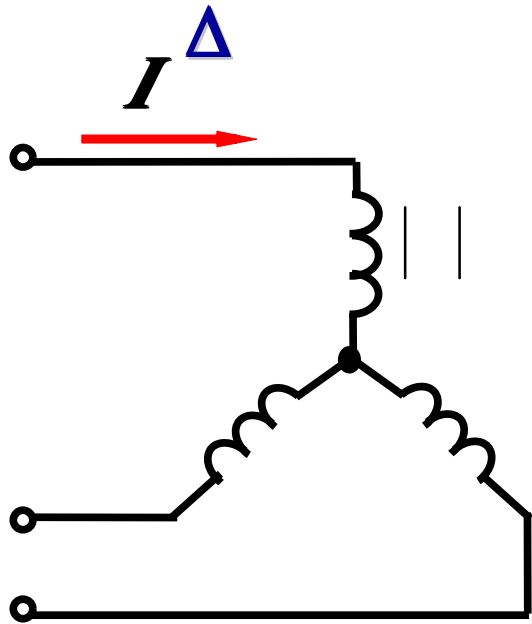

$$I_\Delta = \sqrt{\frac{|Z|}{3}}$$

$$I = \frac{I_\Delta}{\sqrt{3}}$$

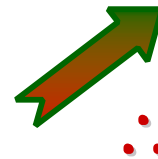

$$\frac{I}{I_\Delta} = \frac{1}{\sqrt{3}}$$



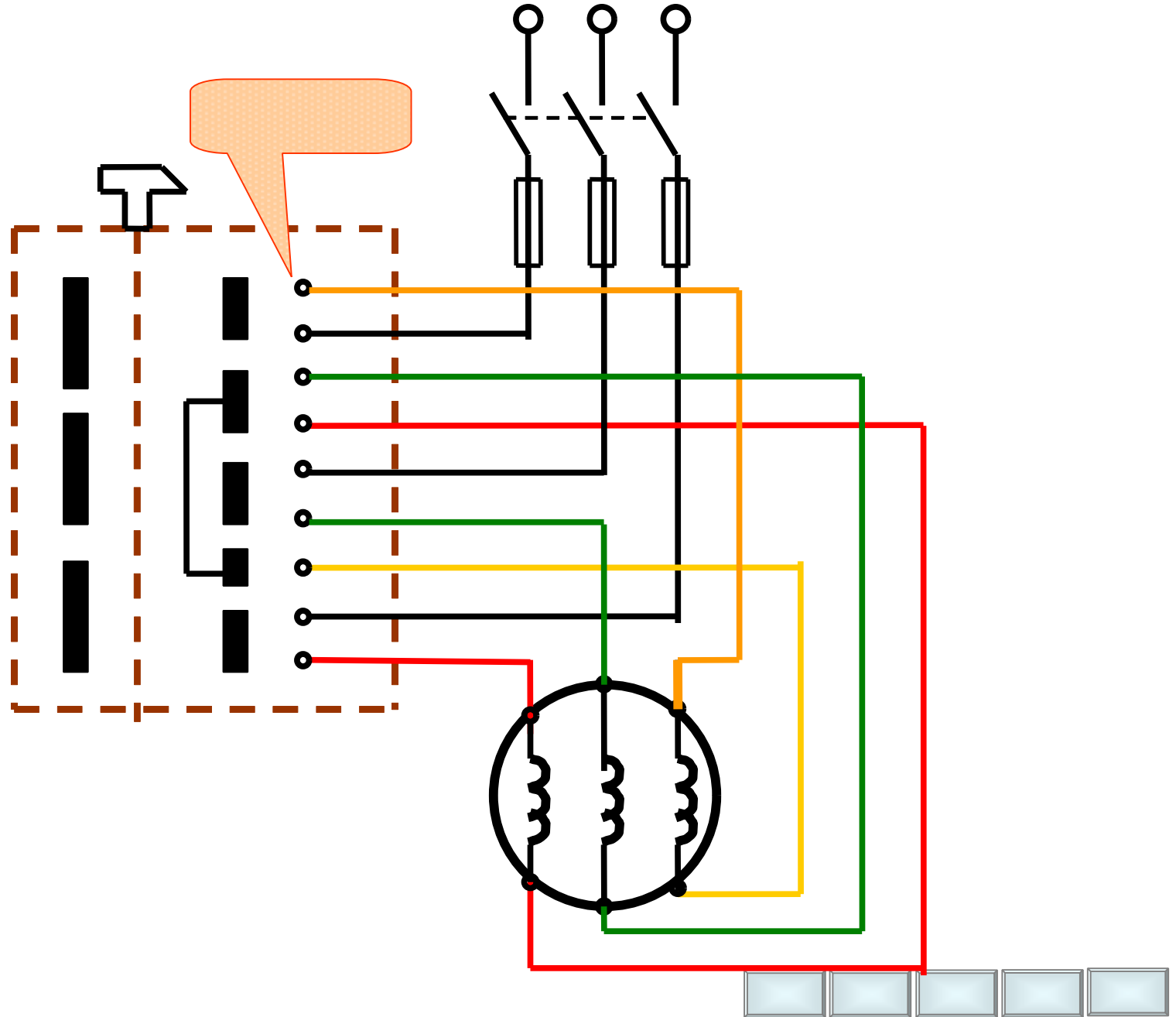



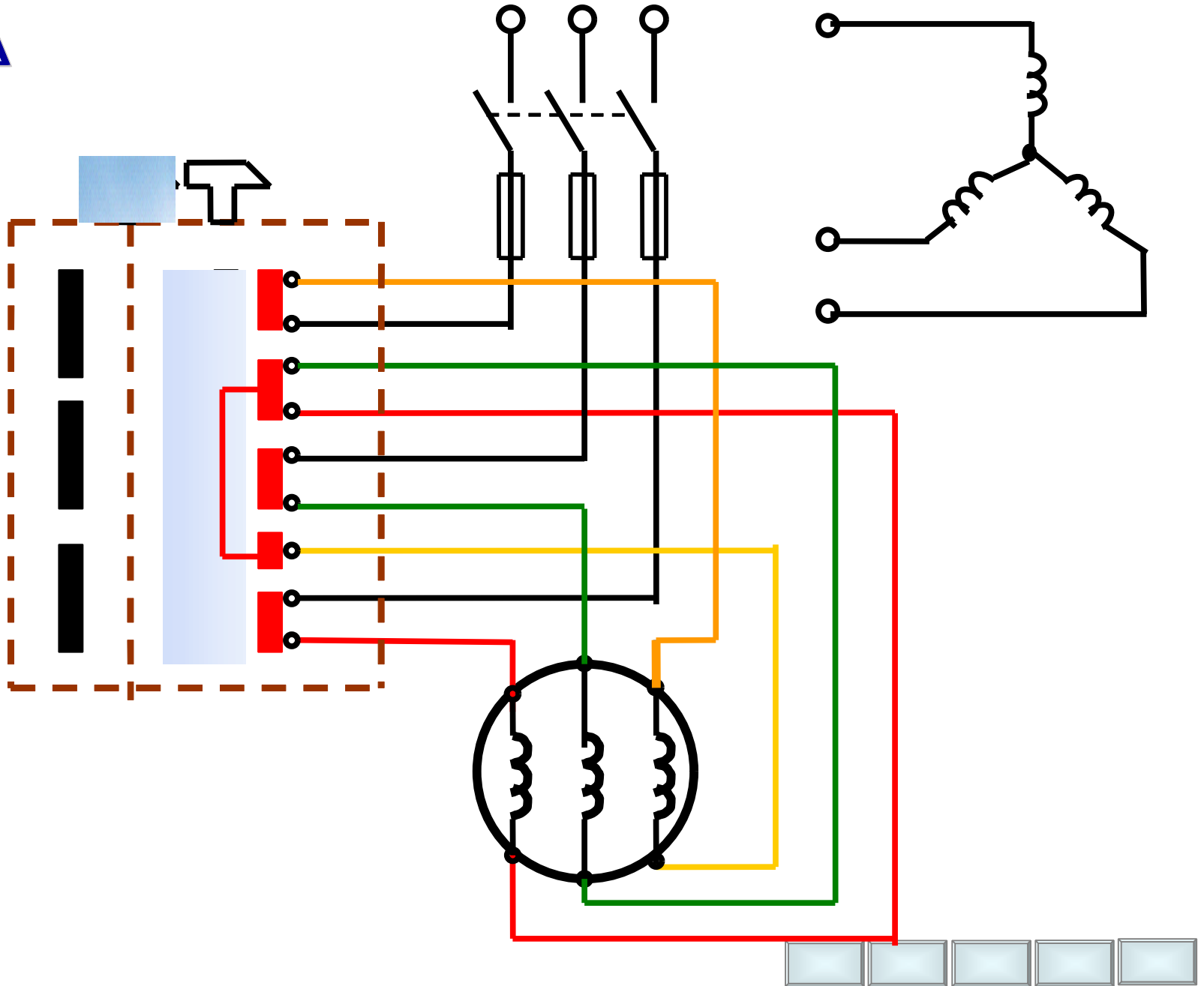

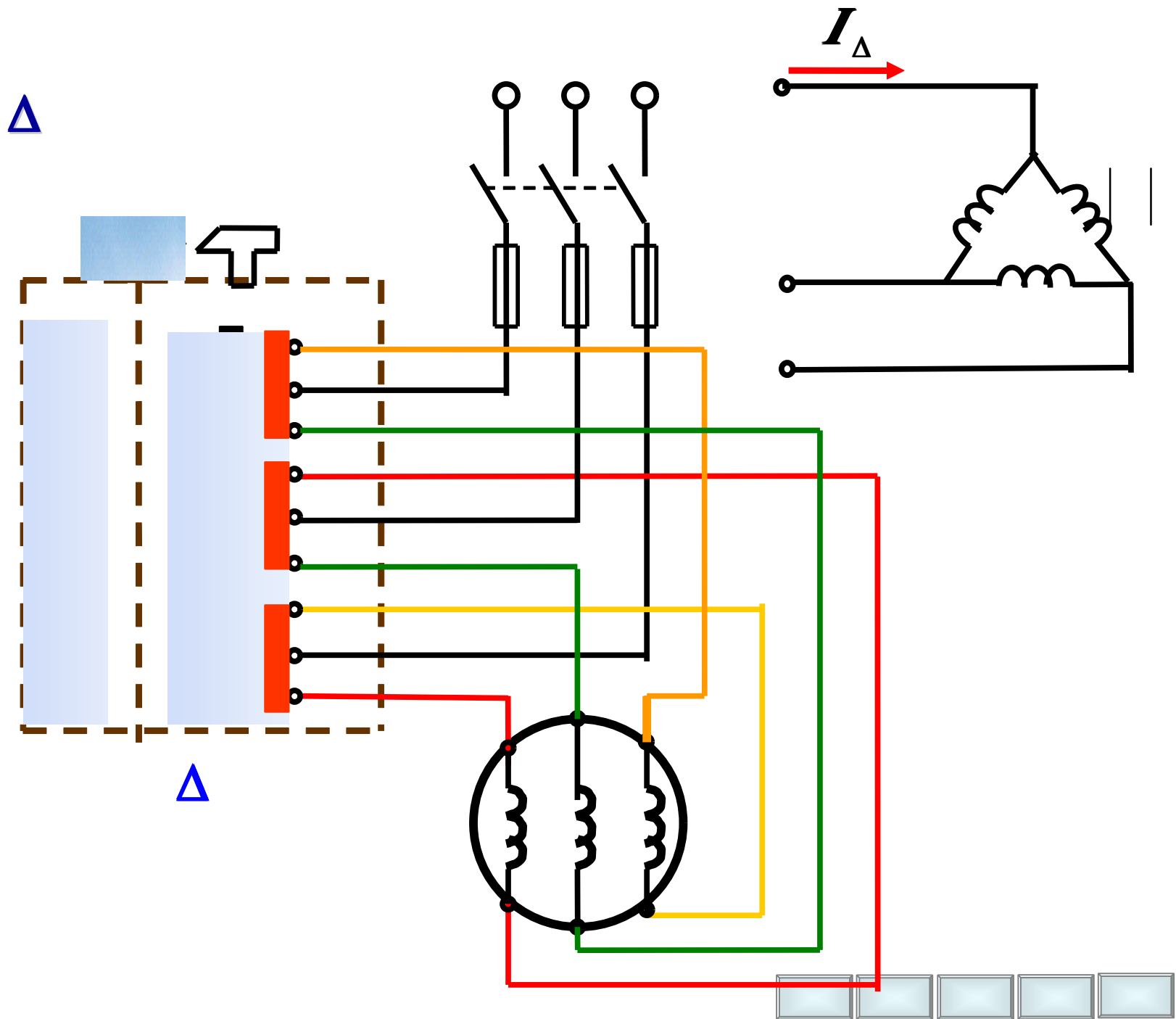

$\Delta$

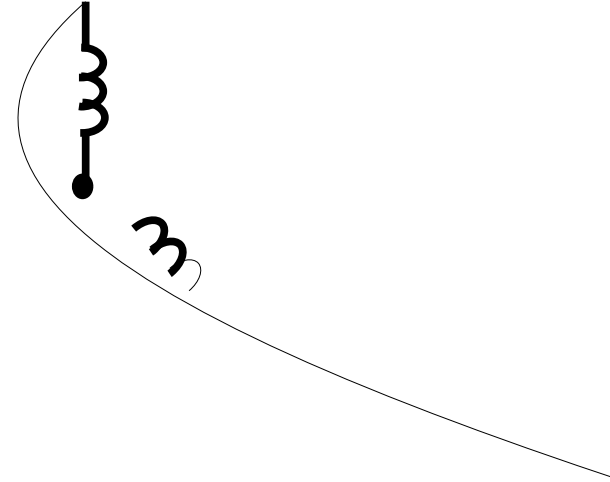

$$\Delta \quad I \quad \downarrow \rightarrow \quad \downarrow \quad \propto$$
$$= \frac{\quad}{\sqrt{\quad}} \quad \rightarrow \quad = \text{---}$$

$\Delta$

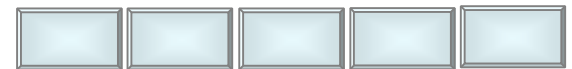
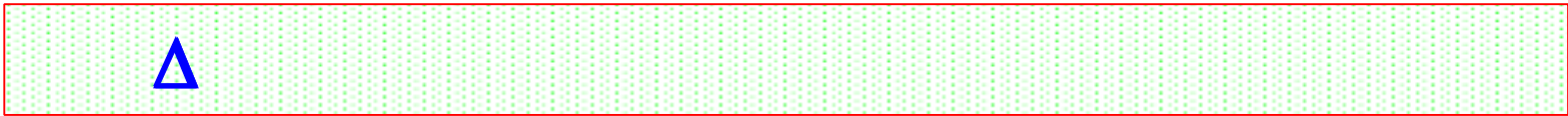



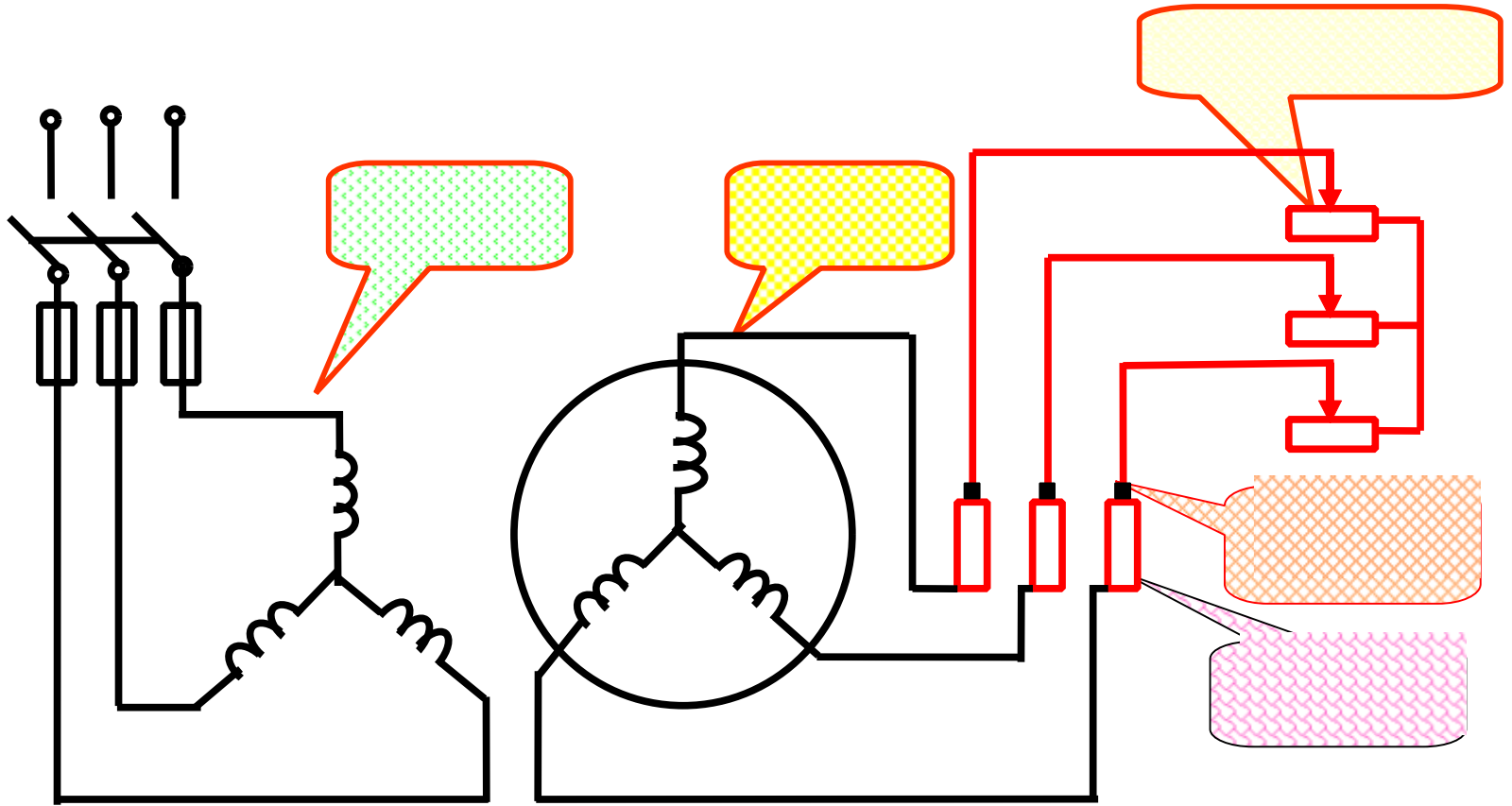

$$I = \frac{E}{\sqrt{r + \dots}} \Rightarrow ' \uparrow \Rightarrow I \downarrow \Rightarrow I \downarrow$$



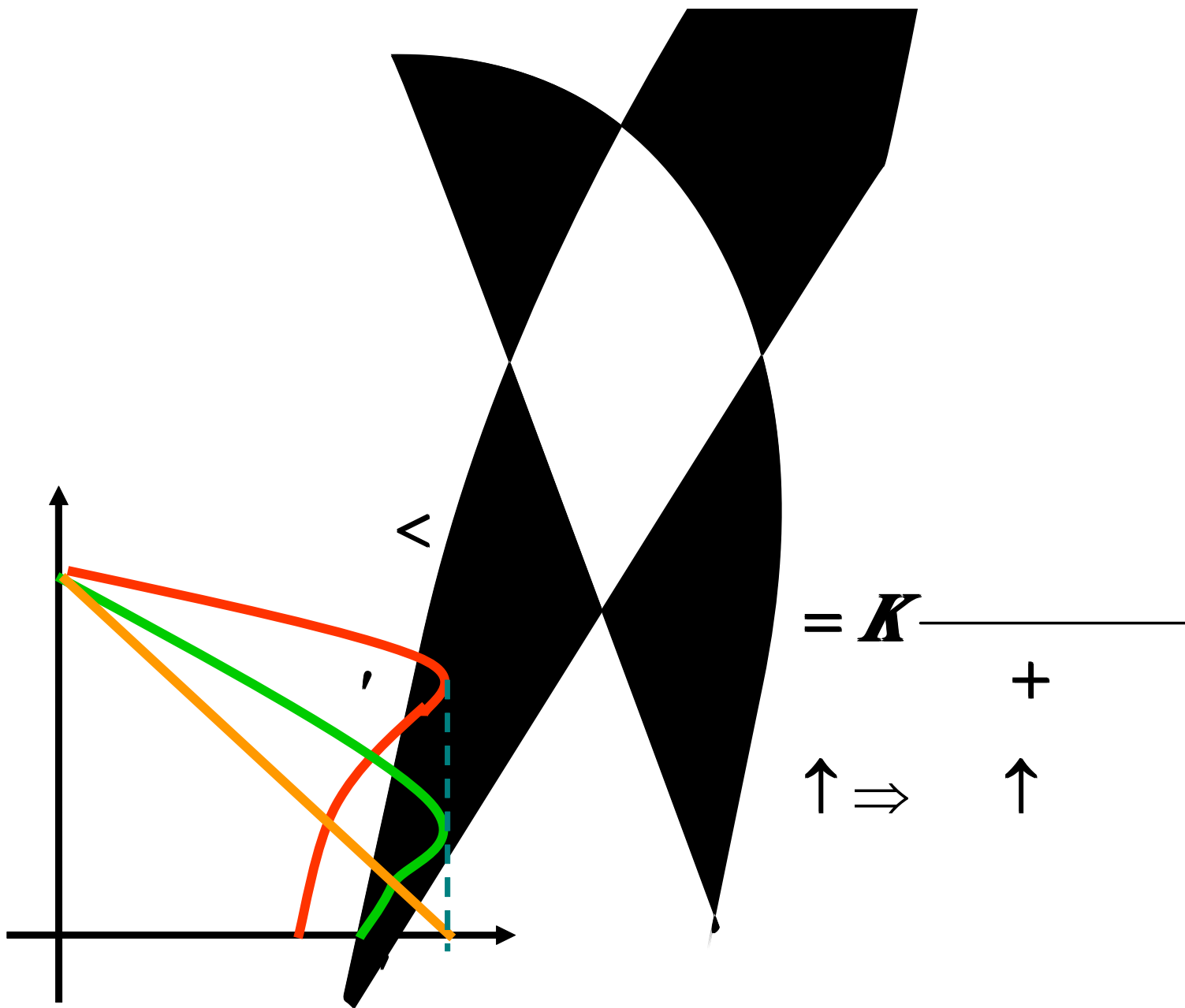

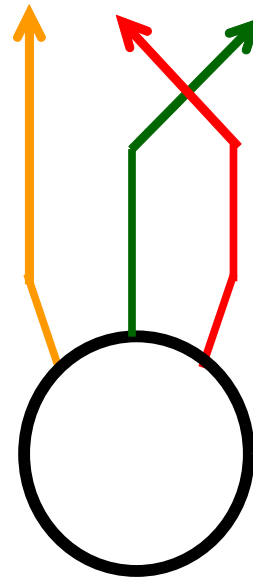
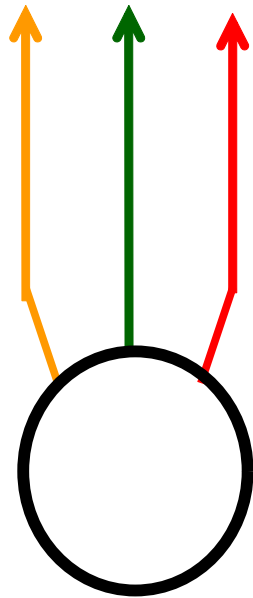

$\sqrt{\quad}$

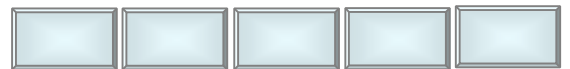





△

= . × . = . < . .



$$I \triangle I \times$$

$$I = -I = -\times \quad \cdot = \cdot$$

$$= - \quad = -\times \quad \cdot = \cdot \quad \cdot$$

$$\frac{\times}{\times} = \frac{\cdot \times}{\cdot \times} = \frac{\cdot}{\cdot} <$$

$$\frac{\times}{\times} = \frac{\cdot \times}{\cdot \times} = \frac{\cdot}{\cdot} >$$



$$I' = \frac{I'}{I} = \frac{\dot{I}}{I} = \frac{I''}{I}$$



$$\frac{I''}{I'} = \frac{\quad}{\quad} =$$

$$I'' = \cdot \quad I' = \cdot \quad \times \quad \cdot \quad I = \cdot \quad I$$

$$= \quad \times \quad \cdot = \quad \cdot$$

$$\propto \quad \text{---} \quad \text{---} = \cdot$$



$I''$

$$I'' = I$$

'

$$' =$$



= ( - ) = ( - ) →

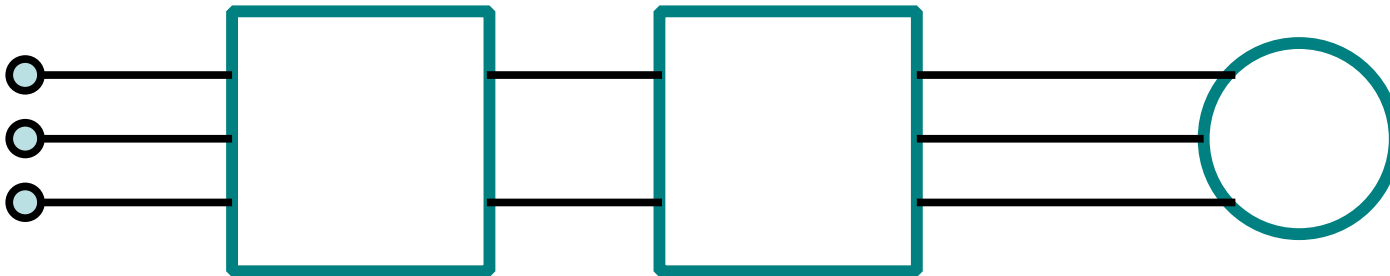

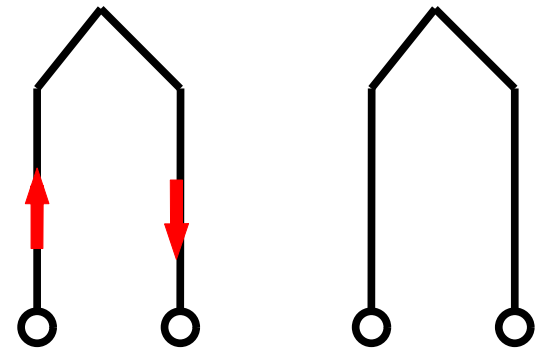





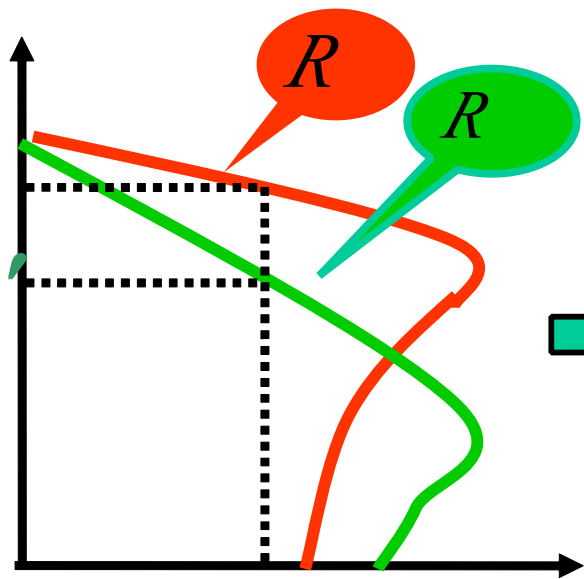

<

